

Harnessing *HEAT*

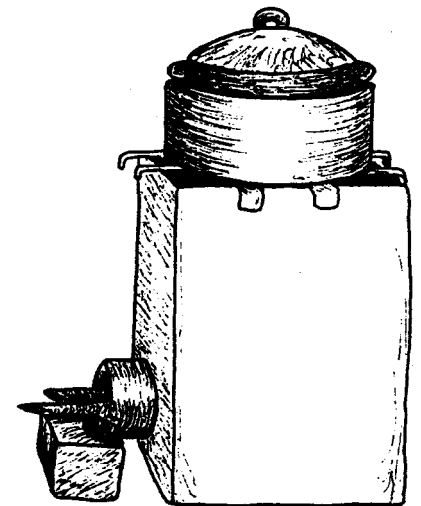
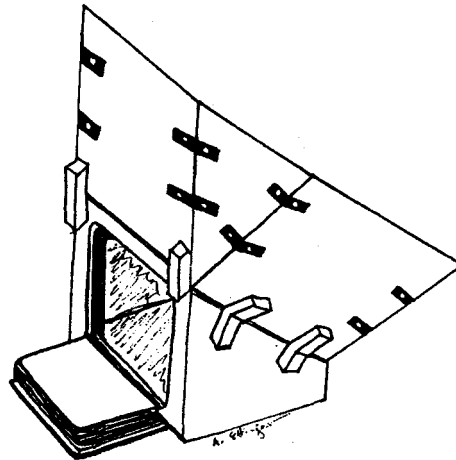
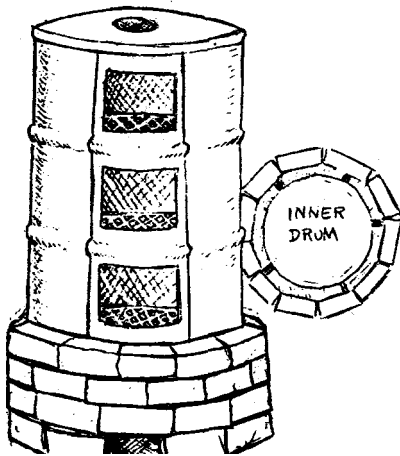
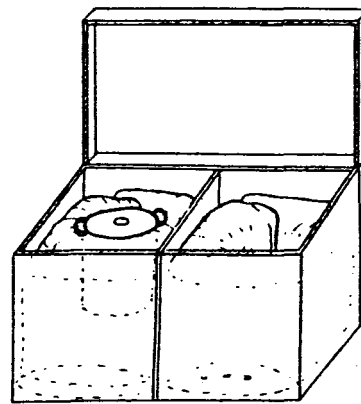
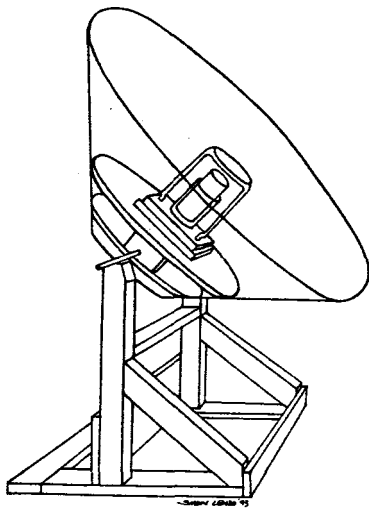

**FIVE EARTH-FRIENDLY COOKING
TECHNOLOGIES AND HOW TO
BUILD THEM**

Capturing ***HEAT***

2nd Edition—Newly revised and updated.

Contents:

4	INTRODUCTION
4	Saving Biomass Resources Worldwide
7	MARIA TELKES SOLAR COOKER
8	How to Design a Powerful Solar Cooker
10	How to Build the Plywood Telkes Cooker
16	CONICAL COOKER
16	Reflections on Solar Cooking
19	THE WINIARSKI ROCKET STOVE (ESTUFA ROCKY)
20	How to Build the Rocket Stove
22	Insulation and High Mass in Stoves (and Houses)
26	Concerning Stove Efficiency
26	How to Make a Rocket Stove with Tin Cans
29	HAYBOXES (INSULATED COOKERS)
31	THE ROCKET BREAD OVEN
33	How to Construct the Winiarski Rocket Oven
35	VISIT THE RESEARCH CENTER

Introduction

This booklet is an introduction to more efficient ways of cooking food using renewable resources. The five stoves and ovens presented here are like well-proven recipes: each has been built and tested and used at the Research Center. They all use solar energy to cook food; some use it directly and others are designed to burn biomass, like wood, that stores sunlight in the form of chemical energy.

Aprovecho uses each new design before teaching people about it, to make sure that a design is worthwhile. The staff at Aprovecho concentrate primarily on household technologies, figuring that cooking is the most important job that is done involving technology. If people don't cook, they don't usually get to eat!

So, here are five "recipes" for ecologically sensitive ways of making the foods that you love. Many of these designs have been built in various countries around the world. Each culture has produced a stove slightly different from antecedent designs. In many ways this process is very much like a recipe where each culture produces exotic and wonderful variations of a theme. We invite you to make your very own stove and then make something delicious with it! Why not share successes, both technological and culinary, with neighbors and friends who might appreciate both?

Saving Biomass Resources Worldwide

Aprovecho has been involved with stove design and cooking systems for more than fifteen years. The Research Center near Cottage Grove, Oregon was created by consultants to the Peace Corps and other Aid Agencies who worked overseas helping to create

more efficient ways of preparing food, raising crops, building composting toilets, cisterns, etc. Today, our focus has widened a bit to include research into solar technologies: desalinators, dryers, refrigerators, water heaters and cookers. The wood burning stove designs have become a great deal more efficient and they fit into an integrated "system" of cooking that has evolved over the years.

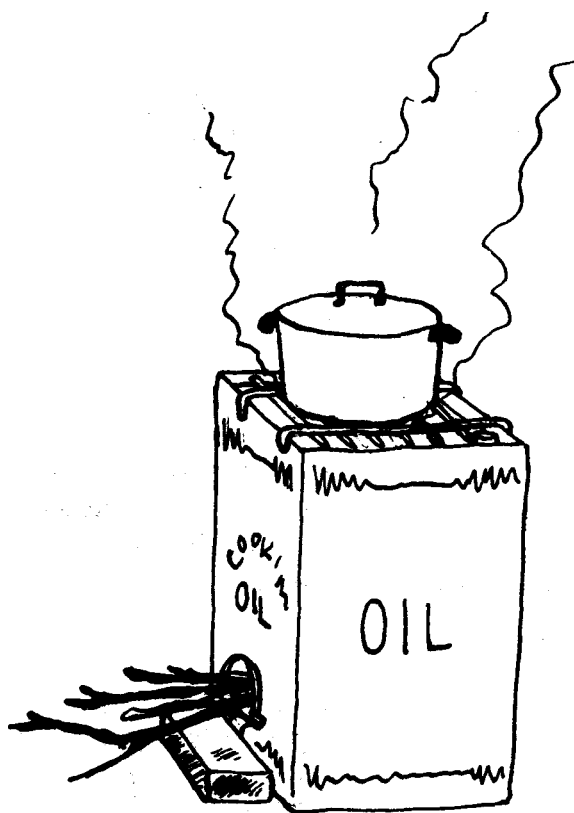

The Winiarski Rocket Stove.

Deforestation due in part to fuel needs represents a major threat to ecosystems in many developing countries. Obviously, the

answer to threatened forests is to grow trees at a faster rate than forest products are consumed. Wood can then be used at a sustainable rate, where less is taken than produced. Taking a greater amount insures a diminished resource and, if the trend continues, an eventual loss. Many countries in the world will run out of wood, long before they run out of gasoline and oil!

No cooking tool will be universally adaptable in different situations and cultures. One design will not be applicable to all settings, because resources, climates, acceptance, patterns of use, etc., vary from place to place. The designs presented here are single attempts at melding working principles with available resources, which includes the human component. All designs are expected to be modified to fit into a given situation. That's why Aprovecho believes very strongly in teaching people to be designers, not in just teaching designs. No single unchanging design can be considered an "appropriate technology"; local people must help in the design process to create a useful appliance.

The five cooking devices make up an integrated system of cooking that allows the user options and choices. Any design will help in cooking more efficiently, but using devices in combination can result in more dramatic

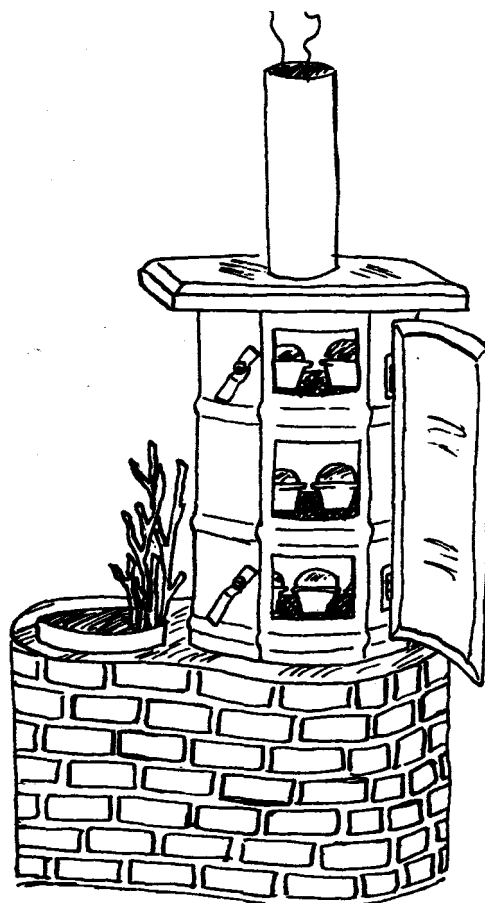

Rocket Bread Oven.

savings. For example, a fuel efficient stove coupled with an insulated cooker can save tremendous amounts of firewood. A fuel efficient woodstove, by itself, saves no more than 30 to 40 percent of the fuel used in cooking over an open fire. The use of an insulated cooker is essential.

This system involves designs that are easy to learn to make. When it's sunny, it's possible to cook using a very powerful solar oven, with many reflectors. You can boil water using sunshine by building a conical concentrator. When the sun isn't shining, which has been known to happen here in the Pacific Northwest, the staff at Aprovecho can cook using a "Rocket" wood fired stove which is very efficient and almost smoke free. Baking is done in

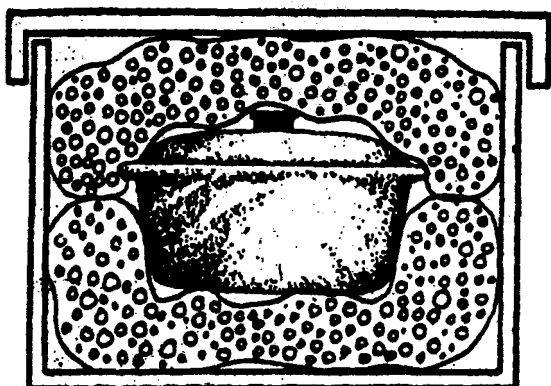

Haybox (Insulated Cooker).

a "Rocket" style bread oven, which is very inexpensive and can bake about 70 pounds of bread at a go. (Both the stove and oven were designed by Dr. Larry Winiarski.) Aprovecho very rarely does any simmering of food. Instead food ready to simmer is placed inside a well insulated box, where it finishes cooking without worries over scorching, boiling over and the like.

It's important for the appropriate technologist to introduce the element most likely to make a positive difference. For example, a Rocket stove can be less helpful than a Rocket bread oven in places where baking consumes a lot of wood. Building a bread oven may be the first priority. Insulated cookers can save more fuel than is gained by replacing an open fire with an efficient wood burning stove.

In a sunny climate, direct solar cooking may be the wisest choice. However, solar cooking is usually slow to be accepted because it is new and slower and a bit limiting. Starting out with a haybox, which is easier to use, might make more sense. In any event, knowing a range of options allows choices when

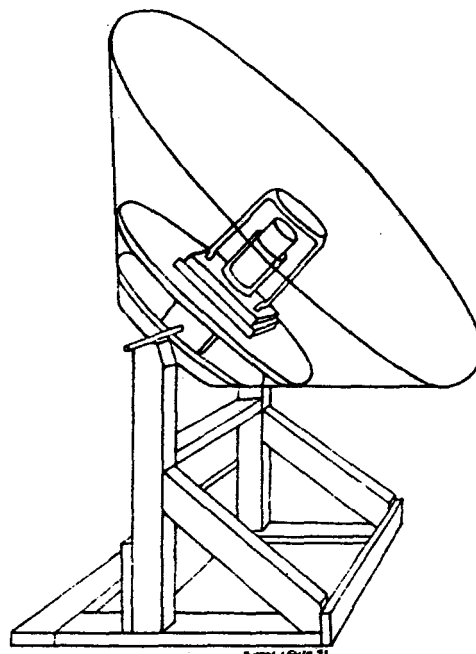

Conical Solar Cooker.

Conical Solar Cooker.

you're concerned with conserving natural resources, whether it's oil or wood or whatever. The appropriate technologist with a hundred designs in the back pocket seems more likely to produce an acceptable device, with local input, than the technologist with only a few designs back there! A good A.T. designer is a combination of engineer, anthropologist and political scientist.

Following are general descriptions for constructing each of these devices. Each is designed to be inexpensive and simple to build. All are in use at Aprovecho and you are sincerely invited to visit and experience these cookers in operation. Please feel free to adapt these ideas and principles to your unique situation and needs. The extent to which your needs end up being satisfied by your cooker, will determine how successfully we have combined to produce an appropriate technology.

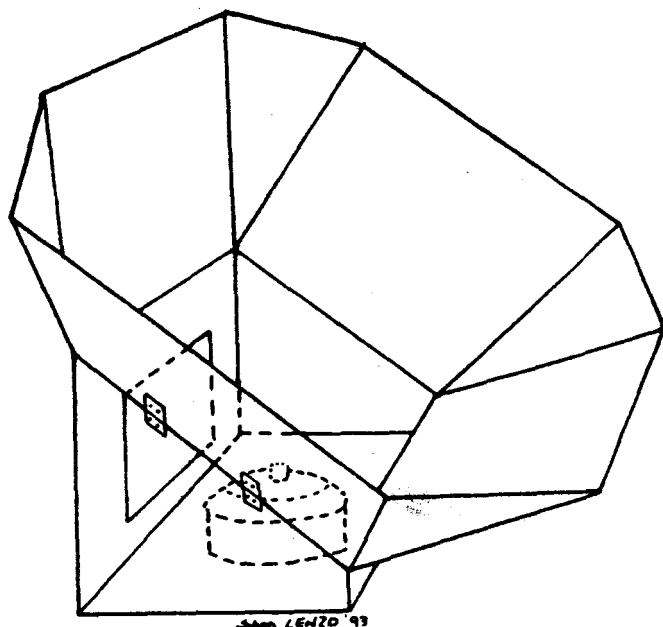

Maria Telkes Solar Cooker.

Maria Telkes Solar Cooker

The solar cooker that is recommended was designed and tested by Dr. Maria Telkes during the 1950's. (Dr. Telkes invented many solar devices. She could very easily qualify as the mother of Appropriate Technology.) This oven easily reaches 300 degrees R and will touch 400 R on hot summer days. It isn't necessary to constantly reorient it, because the stove is powerful enough that it works even when it's not aimed exactly at the sun. We recommend building fairly large scale cookers because solar energy is diffuse. It takes a pretty big reflector and glass top to build up the heat and temperatures necessary for easy cooking. (The cooker in these plans has a glass cover 24" x 26"; we also use one with a

glass cover 30" x 30". This particular design is useful in higher latitudes. Directions are given showing how to adapt the design to all latitudes.)

This solar cooker works well because it combines some important design criteria:

- The box is surrounded by reflectors, which direct visible light down into a box through a glass cover. (On a sunny day, each square foot of earth in sunshine receives about 200-300 btu's of energy per hour. One btu is the amount of energy it takes to raise one pound of water one degree R)

- The box is well insulated and relatively

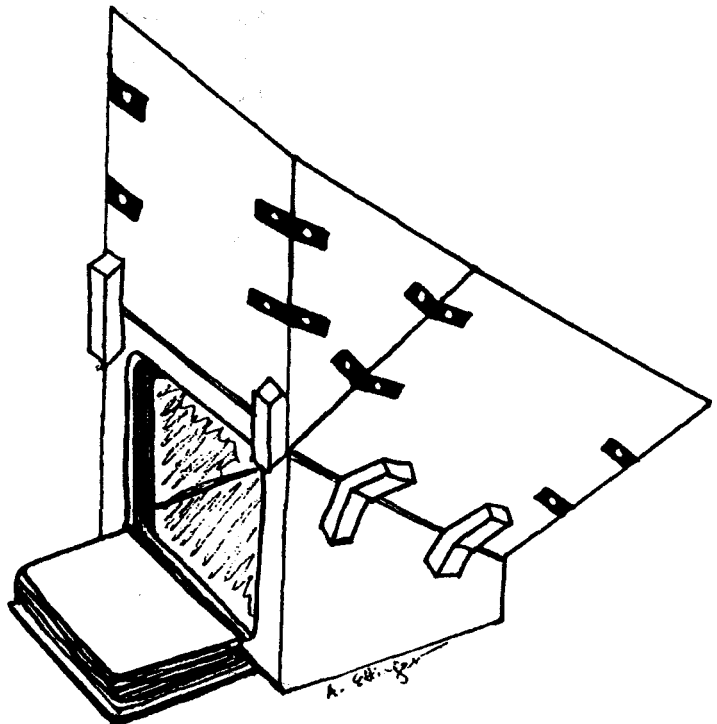

Hot food fresh from the solar cooker.

airtight.

- The glass is at a 60 degree angle, minimizing shading. Double panes of glass help a great deal as the air space in between the panes helps to insulate the box.

- The box is metal lined and painted completely black so that visible light is efficiently absorbed and changed into infrared or heat energy. The infrared energy is absorbed by the glass and its escape is slowed by the insulation inside the walls, so that heat leaves the box slowly enough that internal temperatures can rise.

- The pot sits on a black metal floor so that heat enters the pot through conduction (metal to metal contact) as well as through convection (air to metal contact.)

How to Design a Powerful Solar Cooker

Here is one simple way to design a solar cooker that will work well:

Figure out what you will normally want to cook.

Figure out how quickly you need to cook the food.

Figure out how many btu's you need to cook the food. (As a very rough rule of thumb, figure on needing about 150 btu's per hour per pound of food to cook food in "normal" time periods.)

Depending on your latitude, the cooker will receive between 200-300 btu's per square foot per hour. It's about 300 btu's near the Equator and closer to 200 btu's near 45 degrees North and South Latitude. Only approximately 30% of this energy will actually cook the food.

Size your solar cooker accordingly. For example: A solar cooker with a total of 10 square feet of sunlight directed into the box,

has about 2,000 btu's per hour entering the box when used near Aprovecho. The cooker is only about 30% efficient so about 660 btu's will actually cook the food per hour. 660 btu's divided by 150 equals 4.4. Therefore, about 4.4 pounds of an easily-cooked food (including the weight of the water) can be made per hour in this cooker. Hard-to-cook items will require more time. To accomplish this type of powerful cooking, make sure that:

A.) The glass is as perpendicular to the average position of the sun as possible. With the Telkes cooker, aiming the glass directly at the sun will optimize the effectiveness of the reflectors. The maximum amount of sunlight will be reflected down into the box. Take into account whether more cooking is done during the summer or winter.

To figure out the angle of the sun above the horizon, subtract the local latitude from 90. Then add 23.5 degrees to the result. This will give you the highest sun position in the summer. Subtract 23.5 degrees from the result to find the sun's lowest position in winter. For example, the latitude at Aprovecho is 44 degrees north. $90 \text{ minus } 44 \text{ equals } 46.46 \text{ plus } 23.5 \text{ is } 69.5 \text{ degrees}$. This is the highest point reached by the sun in summer.

$46 \text{ minus } 23.5 \text{ is } 22.5$. The sun only reaches 22.5 degrees above the horizon in the dead of winter. Since Aprovecho does most of its solar cooking in the middle of the summer, we place the glass in the Telkes cooker at 60 degrees. Aim the glass in your cooker at the most advantageous angle.

B.) The reflectors are at 120 degrees to the glass. Another way to say the same thing is that the reflectors are positioned at 30 degrees to the incoming rays of light. The reflectors can be about as long as the glass surface they face. Longer reflectors will only aim sunlight at the opposite reflector. (See diagram A.)

C.) Make the box well insulated, as airtight

How to Construct a Telkes Solar Cooker

Make the box first. Begin by cutting out all of the pieces. In this case we used 1/2 inch plywood.

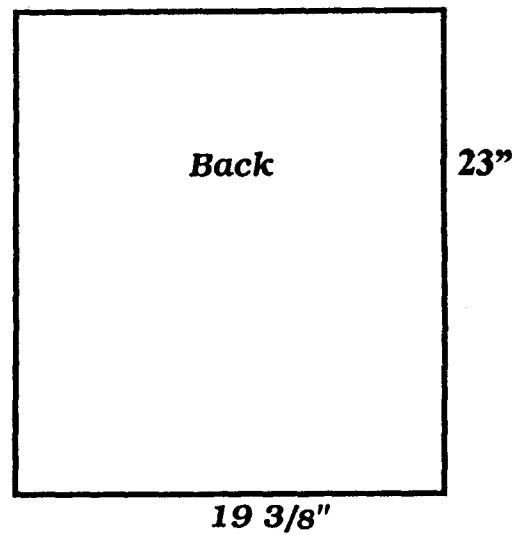
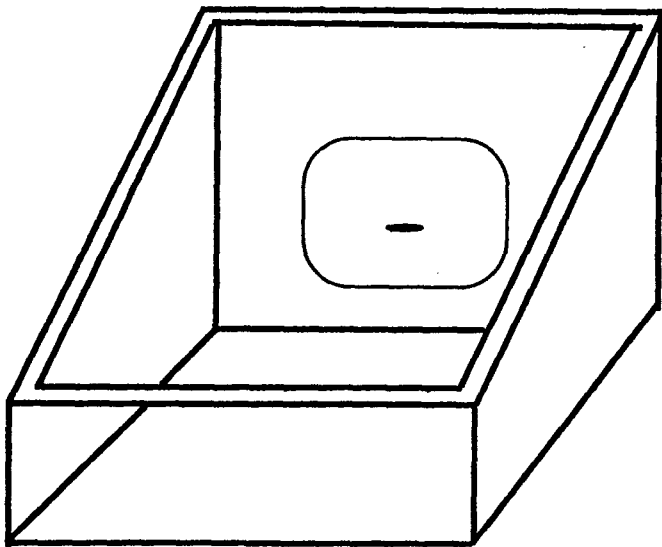

The following diagrams show the sizes of the pieces which make up the box and the reflectors.

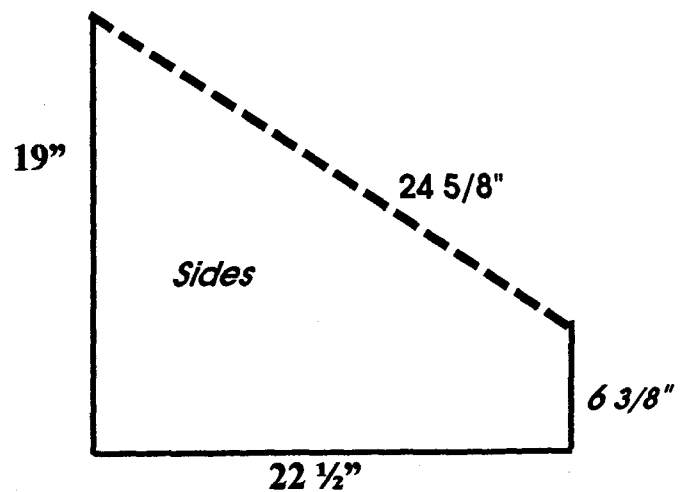
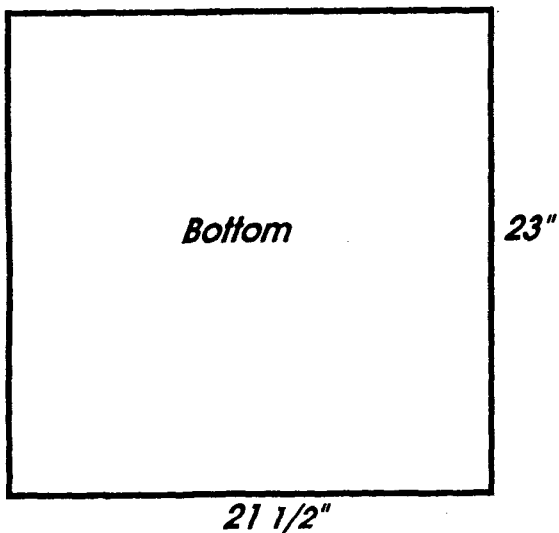
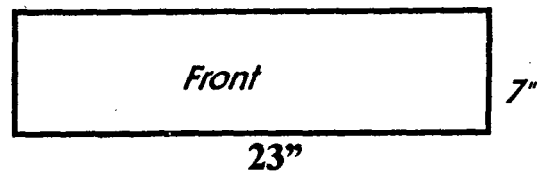

as possible and, if economically feasible, use double panes of glass with a small air gap between the two panes to increase the insulative value of the glass cover. This is especially important in cold, windy climates. Insulation made up of cardboard and aluminum foil works well. Good insulators also include wood ash, charcoal, rigid foam, etc. (See notes on insulation in the Rocket Stove section, pp. 20-23.)

D.) In a Telkes type cooker, paint the inside flat black. Have the black pot rest on a black metal floor so that we take advantage of conduction and convection. (Any part of the interior of the box can be shiny instead of black, if sunlight will hit the surface and be directed at the black pot. Then the pot is most efficiently absorbing the solar energy. In some situations, however, shiny interior walls reflect sunlight out of the box through the glass.)

E.) Since hot air rises, the best theoretical place for the door is on the bottom of the cooker. However, this may be difficult. The Telkes cooker has a back entrance door.

F.) Remember that heat and temperature are two different things. Heat is the amount of btu's available for cooking. The internal temperature of the box is only the point in degrees where the amount of heat gained and lost equalizes. It's important to have a high enough temperature and enough heat energy for cooking to occur. A large Telkes model will be a powerful solar cooker. Solar cookers with less square footage of reflector area will cook at lower temperatures, over a longer period of time.

G.) The square footage that is multiplied by 200 to 300 btu's per hour is not the square footage of the reflectors! It is, instead, the square footage of the intercepted sunlight. (See diagram A.) The Telkes cooker is only one of many. But all designs work in the same manner. Each receives the same 200 to 300

btu's per hour depending on latitude. It is easy to figure out in advance how much energy is available in any design for cooking.

The accompanying diagrams show how to build a medium to large Telkes cooker. This cooker is made out of plywood or sheet metal. In the U.S., it's easiest to make the stove from these materials. It is important to remember that a high mass stove body will absorb a lot of heat that could have initially gone into the cooking process. (A heavy pot will do the same. See "Insulation and High Mass in Stoves (and Houses)", pp. 22-23.) A lower mass oven will heat up much more quickly. The higher mass stove will only assist in the cooking process when the pot is cooler than the stove body. It's important to insulate the stove body from the stove interior by using low mass, highly insulative or reflective materials. A solar cooker made from bricks or earth without interior insulation will waste energy in heating up the stove instead of the food. A solar cooker is also relatively low powered so it's usually better to use the energy directly without storing heat for later use.

It is also possible to make the body of the stove out of scrap metal, such as metal containers. We are confident that it is quite possible to make both the stove body and reflector from any sort of wired together cans or found metal.

How to Build the Plywood Telkes Cooker

Begin by constructing the box first. In this case we used one-half inch thick plywood. Cut out all of the pieces shown in the diagram. Bevel the edges that meet the glass at 30 degrees. Cut the door into the back or sides of the box. Each joint is glued and nailed together.

The glass cover fits over the plywood and is supported by the insulation as well, which

This diagram shows how the reflector is put together.

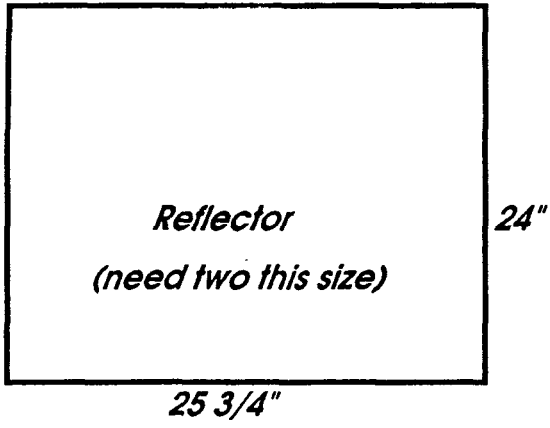

Solar Oven Reflector Wings

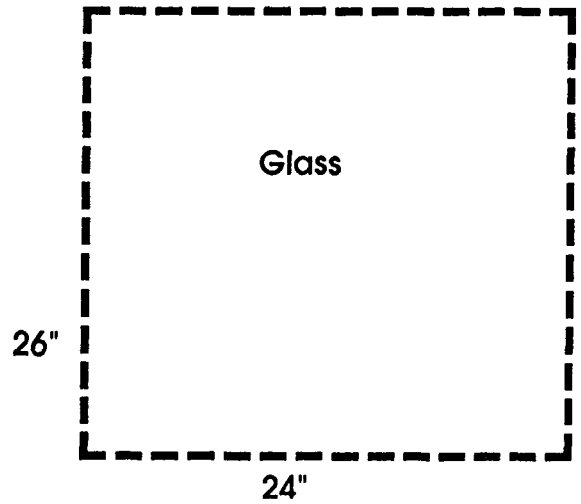
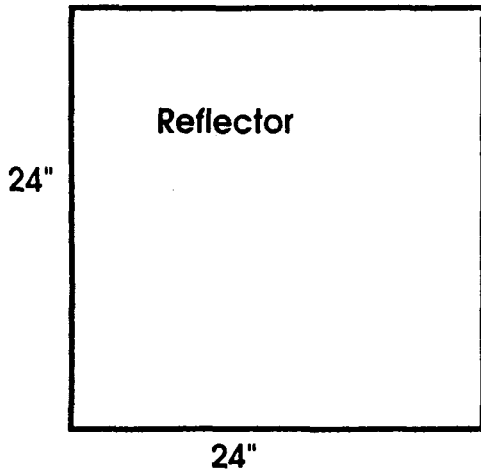
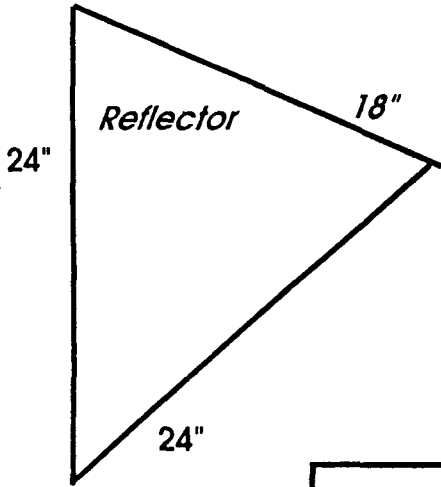
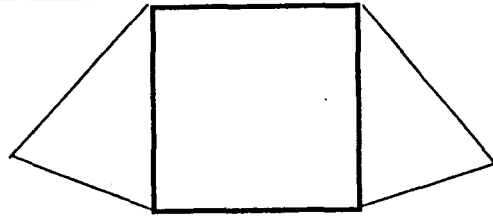
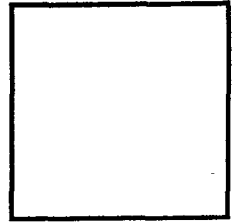
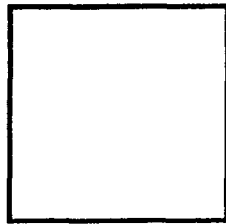
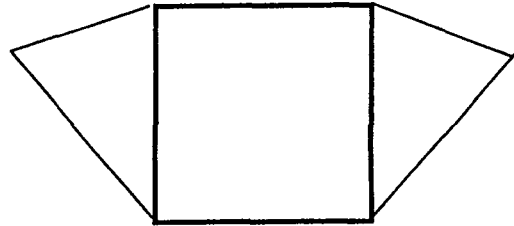

completely covers all interior wooden surfaces. You can nail or glue rigid foam insulation to the walls or build up the one inch thick insulation out of alternating layers of cardboard and aluminum foil. If you choose the cardboard option, contact cement works better than white glue. It resists moisture better. Big washers, with nails or screws, are helpful to hold the cardboard to the walls. Remember that the front and back insulation needs to be beveled. Surround the cardboard insulation with aluminum foil, shiny side facing in towards the food. Make this "package" as tightly and strongly wrapped as possible to keep moisture out of the cardboard. Paint the whole interior black with water based flat paint. Leave the cooker in the sun for a couple of days to burn off the gases from the paint before using the cooker.

The reflector wings, which in this case are made out of 1/2" plywood, need to be supported by some type of brace. We make the braces out of wood. The reflectors meet the glass at an angle of 120 degrees. Hinges hold the reflectors together. It's possible to make the hinges from leather or old bicycle tubing.

The interior of the reflector needs to be covered with something very shiny like aluminum foil or mylar. Contact cement works well.

The box works better covered with two panes of glass. One pane works too. Glue the glass to the insulation and plywood, using a sealant, preferably silicone. The silicone can also be used as a spacer between the two sheets of glass. Leave a small air hole so that the heated air can escape and not build up pressure between the panes of glass.

Remember that the black pot (hopefully, low mass) should sit on a black cookie sheet or painted piece of metal. Make sure that the door fits tightly, try to minimize air leaks! The oven can't get hot with a lot of air infiltration.

Following these criteria will result in a solar cooker that should hover around 300 degrees F. even when full of food. On hot days, beans will cook quickly, bread will bake and brown, chicken will get crispy and french fries will disappear in foaming oil as they fry. The results will impress you!

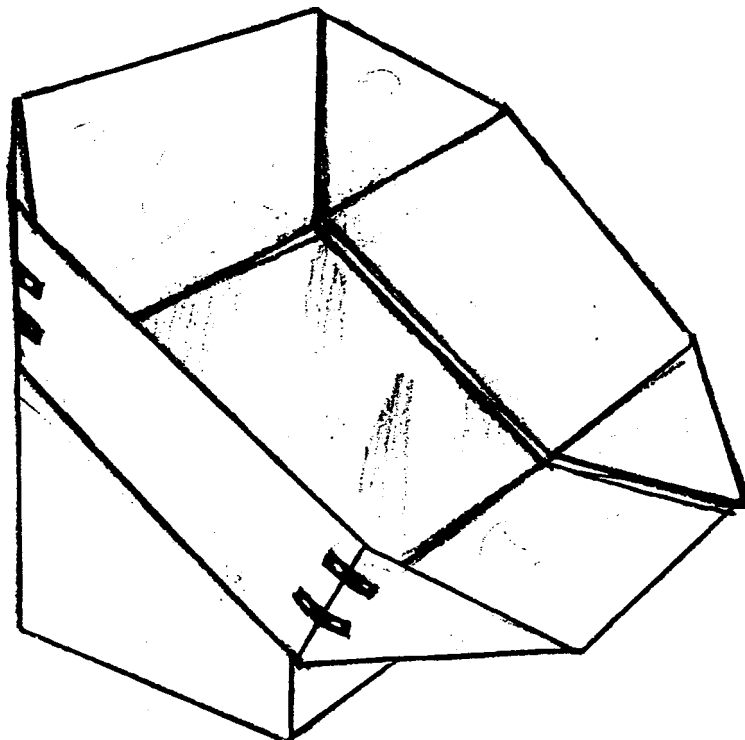

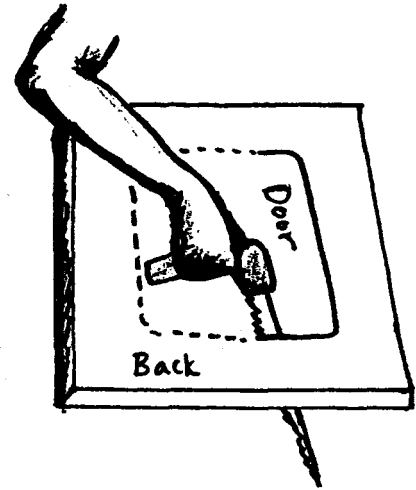
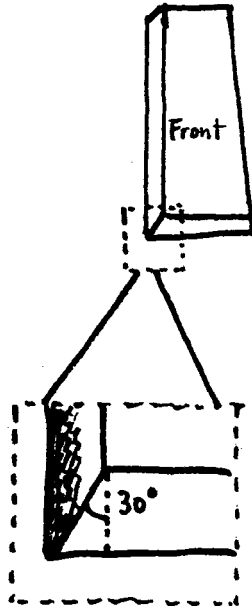
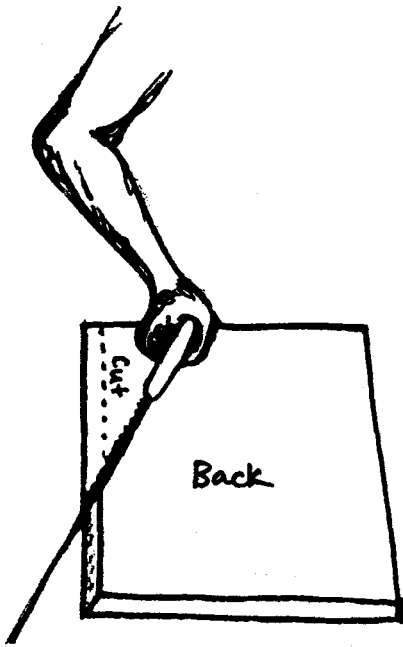

Remember to bevel the front and back panels at 30 degrees.

Cut the door out of the back panel.

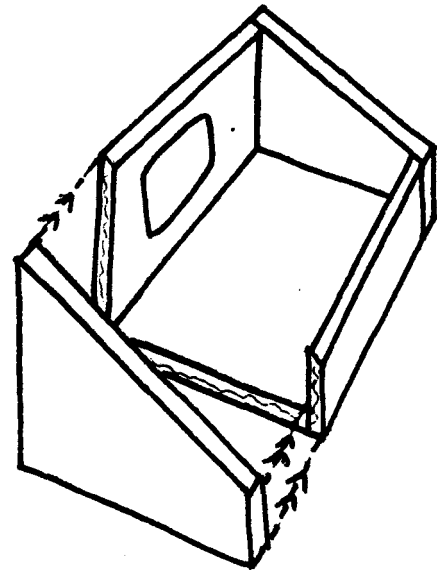
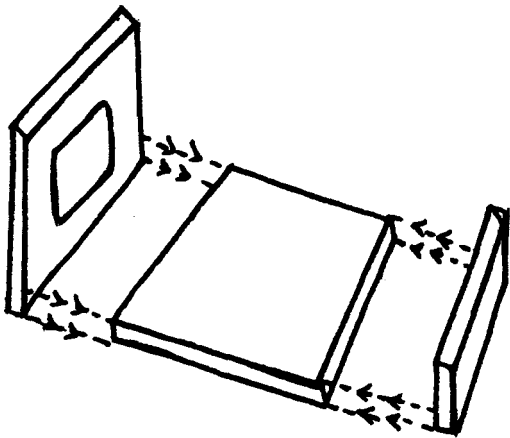

The back and front are nailed onto the bottom

The sides are nailed onto the bottom, back, and front.

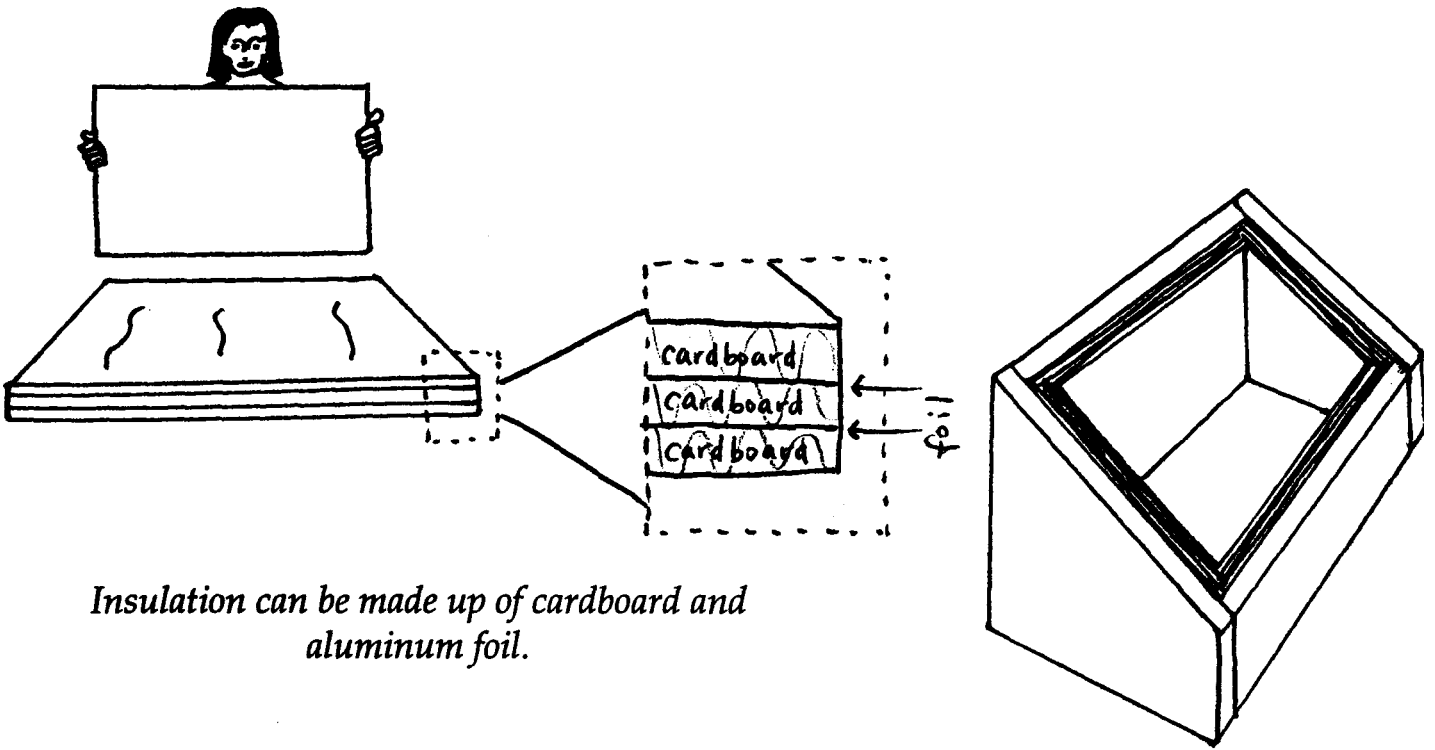

Insulation can be made up of cardboard and aluminum foil.

The cardboard and aluminum foil are attached to the interior of the box using nails and large washers.

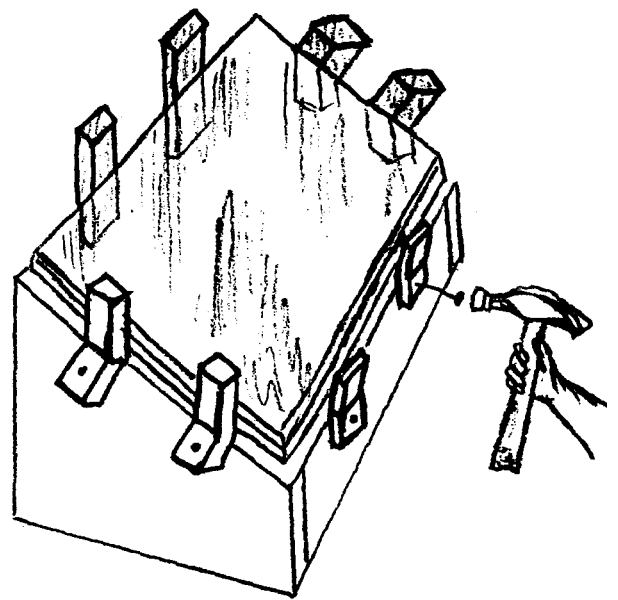
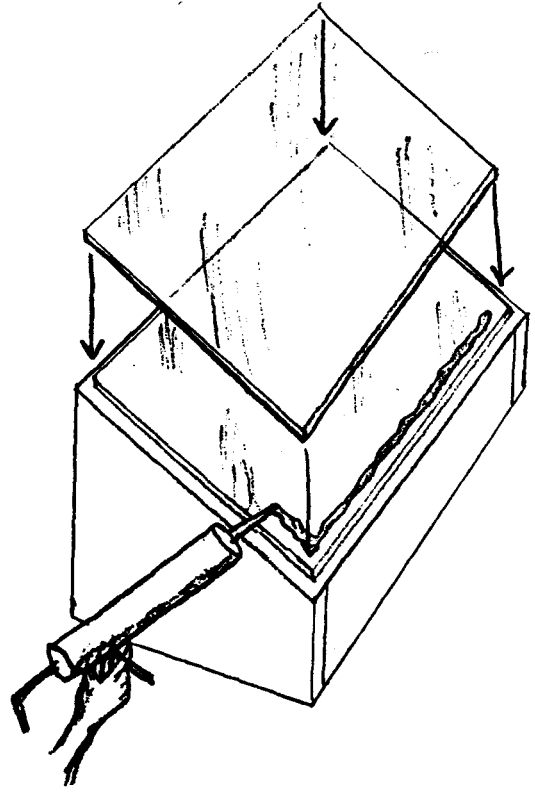

The glass is glued to the top of the box using silicone sealant. If two panes of glass are used, another bead of silicone forms a glass at an angle of 120 degrees are screwed or nailed to the box.

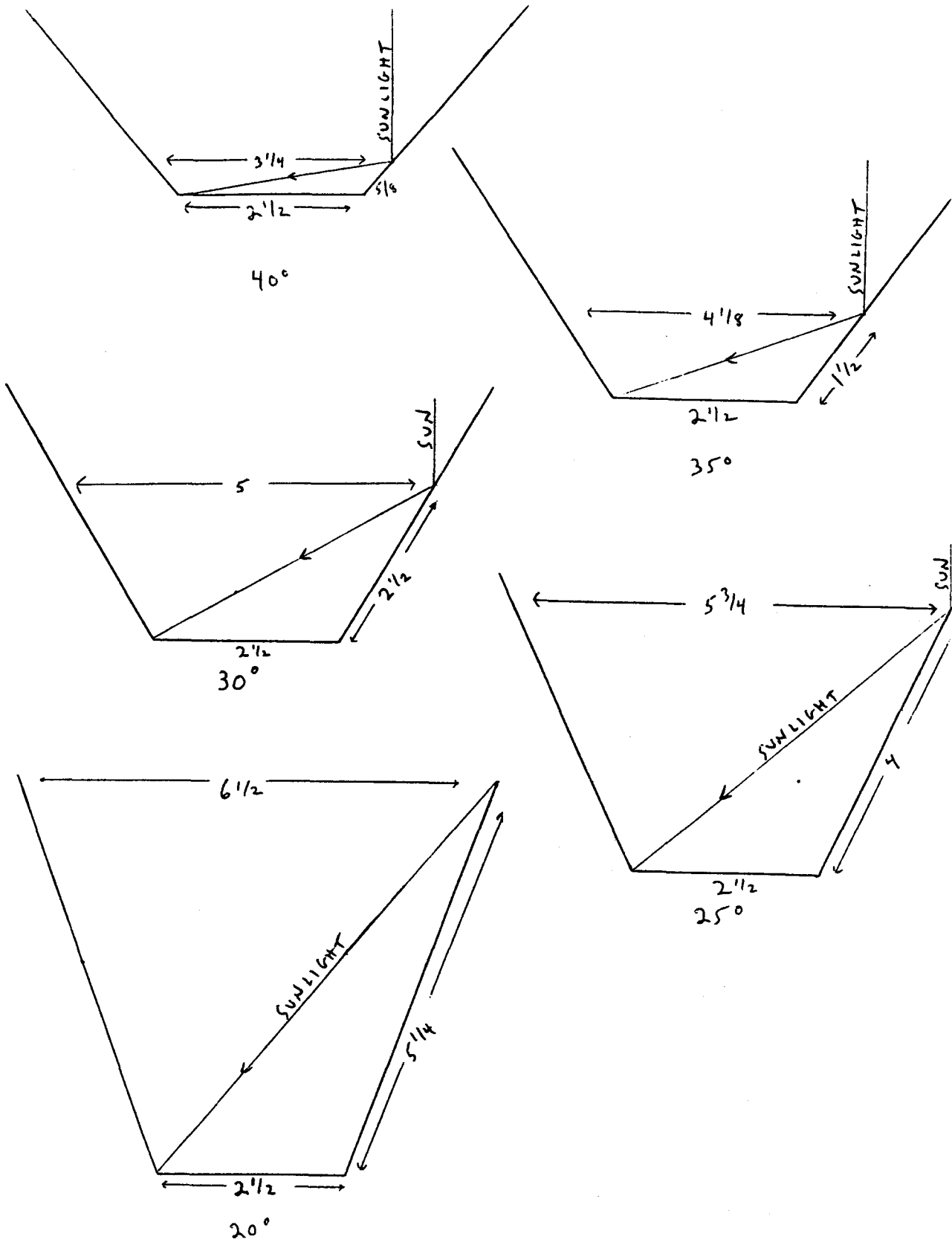

Diagram A: A comparison of varying reflector angles for solar cookers, showing the amount of admitted sunlight and the advantages of a 30 degree angle.

Conical Cooker

Telkes solar cookers are great for baking food. However, the sunlight isn't concentrated enough to quickly accomplish more difficult tasks, like boiling water for tea or coffee. To quickly boil water, it's necessary to use a solar cooker with a different shape. A parabolic dish will concentrate all of the sunlight that hits its surface to a point. If the tea pot were at that point, the water would boil much more quickly than in a Telkes cooker where the sunlight is less concentrated.

There is another shape which concentrates sunlight very well and it's much easier to make than a parabola. This is a cone at 45 degrees. Cones have been used for more than 100 years to concentrate sunlight. They are simple to make and can accomplish many of the same tasks as the more difficult-to-make parabola.

The French mathematics professor, Augustin Mouchot, invented the conical cooker in the 1870's. The cooker that he used in Africa was a truncated cone with a glass-enclosed metal pot in the middle. The cooker concentrates light into a line that forms the central axis of the cone. Telkes cookers concentrate sunlight to a plane, 45 degree cones concentrate to a line, and parabolics concentrate to a point. Although parabolics have the greatest amount of concentration, a cone focusing to a line is quite sufficient for boiling up the tea, or even running a steam engine.

Easy construction is a major advantage of conical cookers. To build one you need to draw a wedge of 105.5 degrees out of a circle. Add a couple

of inches to one side of the wedge for a flap that will join the cone together. Cut out the piece and fasten the edges together. This method quickly makes a 45 degree cone.

After forming the cone, you can screw two plywood plates a couple of inches apart to the sheet metal. Pieces of 2 by 4 fill in the gap between the plywood plates. The stand surrounds the cone and two large bolts form an axle for rotating the apparatus to the proper sun angles.

A quart sized can with a hole punched into the top holds the water. It's held in the middle of the cooker by a cylinder, open at the top, made of sheet metal. The can full of water

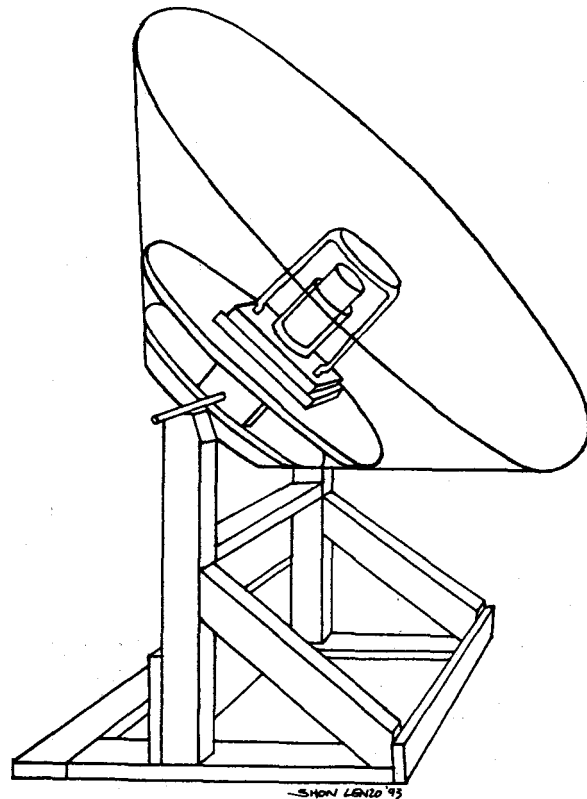

Conical Solar Cooker.

slides about one quarter its length into the cylinder where it's held in place. A one gallon glass jar is inverted over the can and cylinder, providing glazing and insulation.

The interior of the lid from the one gallon jar is cut away, leaving the threaded part. The cut-away lid slides down over a quart sized can and is fitted into a circular hole cut in a piece of lumber attached to the plywood. The one gallon jar screws into the lid and can be taken off and be replaced, using pot holders, a towel, etc. The jar completely encloses the water in its can. (Please see the drawing.)

The conical boiler is aimed by the "nail method". A long nail or dowel is nailed into the plywood base and is fitted so that it's parallel to the central axis of the collector. When the nail throws no shadow, the collector is aimed right at the sun!

The sheet metal for our 54" conical concentrator cost about 17 dollars. It was made from part of a 4' by 8' panel of sheet metal. We covered ours with mylar but aluminum foil would also work. We used contact cement as the glue. We've also made conical cookers out of tin cans wired together. Bands of bamboo held the cone together.

The intent in trying the conical was to see if we could make a solar cooker that would boil water in an easier way than, say, a wood fired stove. And it actually is easier to boil small amounts of water in this device, since you just fill the can and aim. There's no fire to start, etc. A pint of water will

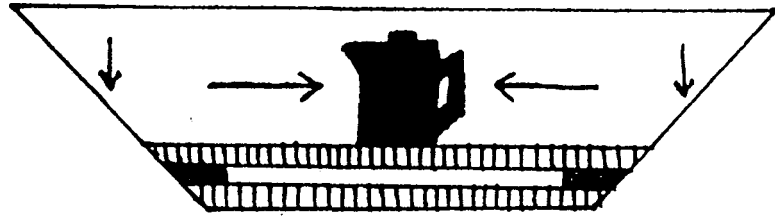

Two plywood plates are screwed into the cone; 2 x 4 spacers fill the gap.

usually boil in less than 12 minutes.

When much more hot water is wanted, it's probably easier to fill a whole kettle and wait for an hour or two until it boils in the Telkes. The problem is that the sun moves enough that for good results, the conical must be re-aimed at the sun about every 15 minutes. Many people might find this more trouble than planning ahead and using the slower Telkes. But, for "tea for two", in a hurry, there's nothing like a Mouchot conical!

Reflections on Solar Cooking

I worked in Mexico for ten years until moving full time to Aprovecho. This experience pointed out a lot of realities, one of which is that no matter how well a device works in theory, if people don't use it, it doesn't really work at all! Solar cookers are a very good example of this principle, because even though solar cooking "works" it has been

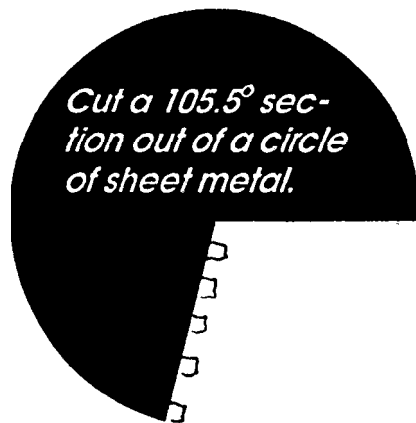

almost universally rejected worldwide. All of the cookers that I first built in Mexico were found unused a year later.'

When asked why the initial cookers weren't helpful people listed the following reasons:

1.) Cooking outside in the sun is uncomfortable and unusual.

2.) The cooker worked too slowly and wouldn't cook beans.

3.) The solar cooker was unreliable and more trouble than cooking with wood or gas.

I hoped that we could find a solar cooker that would be more attractive, since it's very sunny in Mexico and solar cooking is the one cooking method that doesn't diminish an earthly resource. One of the ways that Aprovecho addressed this problem was to try to make sure that the solar cooker was more powerful, to work almost as fast as other stoves. We tried to find designs that were pleasant, and even fascinating, to use. Both the Telkes and conical cookers meet these criteria!

Both can perform rapidly and reliably. The conical can make boiling water for coffee or tea very rapidly. But, it can be irritating to use because of the glare. The Telkes has no problem with glare because the light is directed down into the box. But since it is less concentrating it takes a long time to boil water.

Different shapes seem best suited to different solar tasks. A box with a glass top (a flat plate collector) is great at heating water for bathing. With one added reflector (a "Solar Box Cooker") temperatures will rise high enough to do slow cooking. Adding

a full array of reflectors (a Telkes cooker) raises the temperatures and amount of btu's to the point where faster cooking can be done. A conical or parabolic can do concentrated tasks, like boiling or frying, as quickly as any other stove. But, as the cooker becomes more concentrated, it needs to be aimed more frequently and can have trouble with glare. Both the cone and parabola concentrate sunlight by focusing it in front of the reflector. The Telkes reflects sunlight downwards into a box, below the reflector.

The Telkes cooker is easy to recommend. It convinced me, a solar sceptic, that solar cooking is a viable possibility. A Telkes cooker with a 24 by 26 inch glass cover will cook food easily and quickly. We've used one now for years. I believe that powerful solar cookers are easier to accept than slower cooking models. But, a large solar cooker is not mobile, it can be expensive to build, and still requires a change in cooking routines. All solar designs should be considered because no one design will be universally "best."

Of course, the solar cooking option that is almost universally accepted is to burn biomass. Wood and other plants have stored direct sunlight in a chemical form through the mysterious process of photosynthesis. Direct solar energy is diffuse; wood has a built-in concentrated advantage.

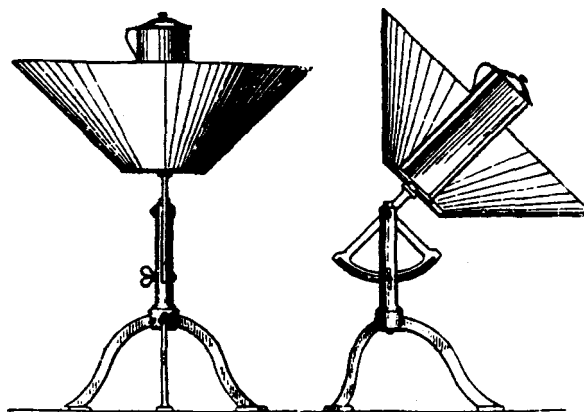

The original Mouchot design.

The Winiarski Rocket Stove (Estufa Rocky)

One pound of dry wood releases about 8,600 btu's of energy when burned. Gasoline is only about twice as concentrated. It took a long time for the tree to grow. The daily amount of sunlight was captured and changed into chemical energy. In fact, trees are very much like batteries, storing energy. Wood is like a battery that has been storing energy for decades. The energy is concentrated and ready for use at any rate, depending on need. Also, this "battery" does not lose its charge while sitting, cannot spill acid on your pants, and usually smells good!

Burning wood or any biomass also has a great advantage over burning petroleum products. Trees absorb carbon dioxide while growing and release the same amount when burned. The tree reduces the amount of CO₂ in the atmosphere and then replaces it. Burning fossil fuels, made from plants millions of years old, can only increase the amount of atmospheric CO₂, since absorption done by the plants happened so long ago. Burning biomass does not increase the amount of CO₂ in the atmosphere in the same way that burning petroleum can.

The 54" in diameter conical concentrator focuses about 10 square feet of sunlight at the pot. Each square foot of earth receives between 200 to 300 btu's per hour on a sunny day. So, the conical cooker delivers about two to three thousand btu's per hour to the pot. That's approximately equal to the amount of energy that's held in a small bit of 2 by 4 lumber only four inches long! The wood is very concentrated and we can burn it as quickly as we want. Direct solar energy is

available at a fixed rate and can disappear behind clouds. If you've got it, wood is a powerful, convenient source of fuel.

By using wood efficiently, people can cook food using branches and twigs instead of split logs. Gathering fallen branches can bring people firewood without killing the trees, if the rate of use matches the resource. The branches are already a handy size so people can be spared the labor of splitting logs as well. The trees continue to grow while people cook with wood.

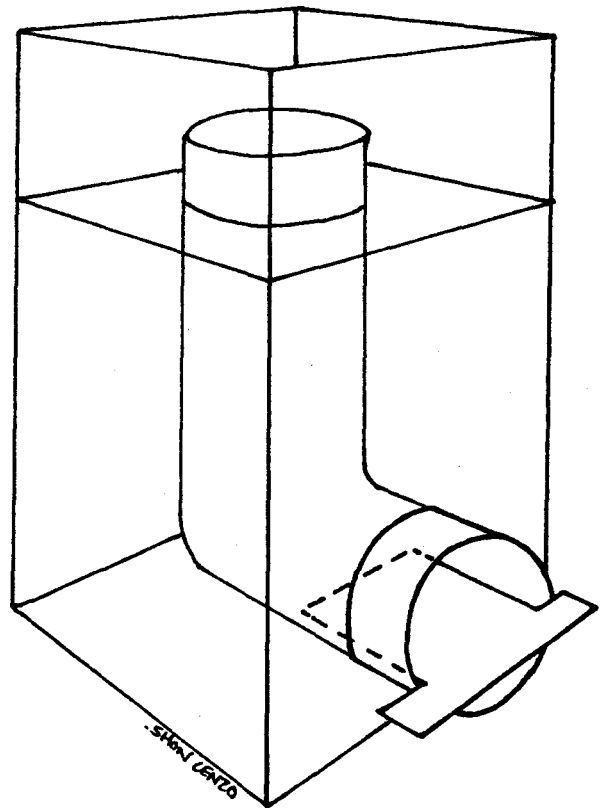

The low mass rocket stove.

Dr. Larry Winiarski's low mass Rocket stove has proven itself to be the most efficient cooking stove that we have used so far. It is far more efficient than high mass cooking stoves like the Lorena. We use Rocket type stoves now to cook, bake, heat water, warm houses, etc.

The Rocket stoves are based on an ingenious combination of principles:

The combustion chamber is insulated in order to keep the fire hot (above 1,100 F.) to burn the wood more completely, reducing smoke which is uncombusted fuel.

The cooking stoves are low mass, robbing less heat from the pot.

An insulated chimney creates a very strong draft which helps the wood to burn fiercely. It also makes the stove easier to light and to use. An insulated chimney has significantly more draft than an uninsulated chimney.

The wood is burned at the tips and is shoved in towards the fire which controls the rate of burn, reducing smoke.

The air/fuel mixture is regulated. A small opening is provided for incoming air. Too much air just cools the fire.

The incoming air is preheated, especially in a downdraft stove, which helps to keep the fire above 1,100 F. for complete combustion.

A skirt surrounds the pot on all sides. A small gap between the skirt and the pot allows hot flue gases to rise up near the pot, greatly increasing heat transfer. The flame hits the sides of the pot as well as the bottom.

An insulated skirt reduces heat loss.

Since the stove operates at very high temperatures, there is almost no smoke and it is possible to cook directly on top of the chimney. The flame, in contact with the pot, assures efficient heat transfer.

The "Guatamalan" Rocket stove is made up of six parts. Two of them are cut out of any five gallon metal container. This makes the external body of the stove. We've used soy sauce containers, paint buckets, etc. A short chimney (10"-12" is optimal) is made, in this example, from stove pipe. It's also possible to make the chimney from tin cans or more sturdy scrap metal. (A longer chimney will smoke less and may be preferable for that reason.)

How to Make the Stove

With a can opener or hatchet, etc. take off the lid of the can.

Then cut a 4" round hole in the middle of the lid and a 4" round hole in the lower front side of the can, about 1" up from the bottom of the 5 gallon can.

A 4" stove pipe elbow at 90 degrees is placed inside the can with the larger end protruding out the hole cut in front of the can.

Two parallel cuts, 1/2" apart, are made in this protruding section of elbow, on the lowest side of the pipe. This section is folded down, creating a lip so the elbow can't fall back into the container.

A straight section of 4" chimney pipe is then fitted to the other end of the elbow as a chimney. It is cut off 1" below the top of the can. (Remember that a short chimney is more efficient. A long chimney will keep flame from hitting the pot. Conversely, a taller chimney will produce less smoke.) The lid, with a hole in the middle, is fitted over the straight section of chimney pipe, after the space between the chimney and stove body is filled with lightweight insulation.

Insulation is small trapped pockets of air. It is this air that slows down heat transfer. Sand, brick, earth, cement, etc. do not contain many

HOW TO MAKE THE STOVE

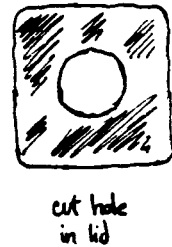
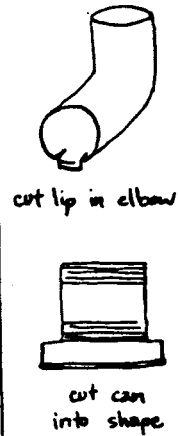
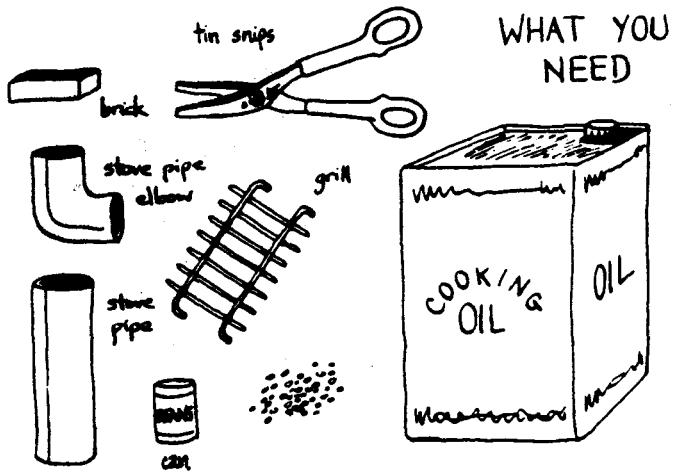

The "Rocket" Cooking Stove



FILL CAN WITH ASHES

The "Rocket" stoves are based on the following combination of principles:

INSULATE AROUND THE FIRE:

A HOT FIRE WILL BURN MORE OF THE COMBUSTIBLE GASES RELEASED FROM THE WOOD

INSULATE AROUND THE CHIMNEY:

CREATES MORE DRAFT WHICH HELPS THE WOOD BURN FIERCELY AND KEEPS THE FIRE GOING

DON'T USE HIGH MASS MATERIALS:

HIGH MASS MATERIALS ROB HEAT FROM THE FIRE. WE WANT THE HEAT TO GO INTO THE FOOD, NOT INTO THE STOVE.

BURN THE WOOD AT THE TIP:

LESSENS THE SMOKE. SMOKE IS UNCOMBUSTED FUEL.

PREHEAT THE AIR/REGULATE THE AIR AND FUEL MIXTURE

TOO MUCH AIR ONLY COOLS THE FIRE.

MAKE A SKIRT AROUND THE POT:

ALLOWS THE HEAT TO CONTACT THE SIDES AS WELL AS THE BOTTOM OF THE POT, WITH A COVER IT'S EVEN MORE EFFICIENT

COOK ON TOP OF THE CHIMNEY:

SINCE "ROCKET" STOVES BURN MOST OF THE SMOKE, COOKING ON TOP OF THE CHIMNEY IS POSSIBLE

The fire chamber and chimney can be made out of tin cans, if desired. The tin cans will last about three months. The cans can be covered by as thin as possible a covering of clay/sand/straw mixture which will become a fired chimney.

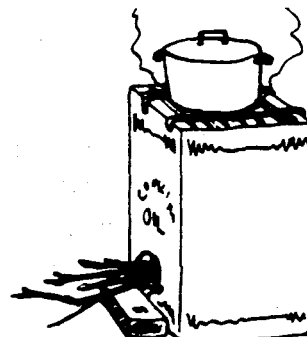

trapped pockets of air and are poor insulators

Examples of good insulation include: pumice rock, vermiculite, perlite, wood ash, dead coral and aluminum foil, if it traps air.

Usually, we use wood ash. As long as it stays dry, wood ash is a great insulator and it is found near fires.

To finish the stove make a pot support, similar to a grill, out of heavy gauge fencing or wire and place it on top of the container. Alternatively, it's possible to rest the pot on top of the container itself. In this case, it's necessary to cut large holes in the top of the container so the air can flow unimpeded past the bottom of the pot. These holes should have the same cross sectional area as the chimney and firebox, in this case 4" in diameter.

Then, make the flat shelf that fits inside the fire chamber and helps to separate the sticks. The shelf can be made out of a flattened tin can and slides into the combustion chamber. The stove will be much more efficient if used with a skirt around the pot. The skirt is simply a sheet of metal that is as high as the pot. The skirt surrounds the pot, leaving an even gap of about 1/4" between the skirt and the pot, so the hot flue gases are directed to contact the pot sides. The skirt gap is equal to the cross sectional area of the chimney. An insulated skirt is double walled with insulation between the walls.

We use the Rocket stove at Aprovecho and we recommend it. It's much easier to use than an open fire and uses less firewood. Please let us know what you think of it. Help us to continue its evolution towards perfection!

Insulation and High Mass in Stoves (and Houses)

The Maria Telkes solar cooker gets very hot

almost immediately if it's empty and aimed at the sun. But, full of beans and rice, it takes a while to reach higher temperatures. The mass of the food and water absorbs the heat initially. The old Lorena stove, which Aprovecho helped to design, is so heavy that a lot of the heat goes wastefully into the stove, instead of into the pot of food! Sand and clay and earth are not good insulators.

An earthen or cement Rocket stove takes a long time to heat a pot of water, when first started. All of the mass in the stove is "robbing" heat from the pot, where you really want the energy to go. That's why we use low mass insulation around the fire in our current designs.

With low mass insulation the heat can do its job with less waste. The small isolated pockets of air in the insulation do not absorb much heat, and heat passes very slowly through insulation. Sand, clay, earth, etc. do not insulate well because they do not contain many isolated pockets of air.

Remember it's the air in a material mat creates the insulation. The function of the material around the air is only to separate the air pockets. Usually the more the material weighs, the more it absorbs and diverts the heat. A Rocket heating stove uses high mass, heavy materials to capture heat that would otherwise flow up out of the chimney and out of the room. The high mass sucks up heat and stores it. In a heating stove, mass can play an important role. But, in the case of a cooking stove, mass just takes heat from the pot and lowers efficiency, especially when starting the cooking process.

Mass is necessary in solar buildings to absorb and store heat from the sun. An empty room, full of air, won't store very much heat. But a cement wall will get hot enough to keep the room toasty all night long.

This room will stay warm for a much longer

time, however, if it is insulated. In a good solar house, the mass is contained inside the building and is surrounded by insulation in the ceiling and walls. A high mass house, in which the walls are built out of earth or cement, will have troubles if it doesn't have insulation on the outside. The high mass in the walls will suck up a tremendous amount of heat and lose it to the outside.

You'd need to make an earthen wall four feet thick to equal the insulative value of 3.5 inches of fiberglass insulation (R-11). Heat will easily pass through earthen or cement walls, and it will take a lot of energy to heat the house.

For this reason, the best adobe houses had double walls. The air space between the walls acted as insulation which blocked the flow of the heat from the inside to the outside. If a high mass house has external insulation, the heat that has been trapped in the interior mass will be contained. But without insulation, not only will it take a very long time to heat up the mass, but the heat will only be wastefully dissipated to the outside.

Of course, adobe houses in hot climates did not really need double walls. The major need in the desert was for cooling, and the mass helped in this regard. Uninsulated, shaded, high mass walls will stay at the day's average temperature. In the desert, the average temperature can be quite pleasant. But, in a cold cloudy climate, the average temperature is too low for

comfort. An uninsulated, earthen-walled house in that type of climate ends up refrigerating its occupants.

High mass houses have also been buried underground. The benefit is that the house, in contact with the earth, will stay at the temperature of the earth, which is about 58 degrees F. However, this house too, if it doesn't have exterior insulation, will require heroic efforts to raise the interior temperature. Without insulation, the heat will, in effect, be trying to raise the temperature of the entire Earth.

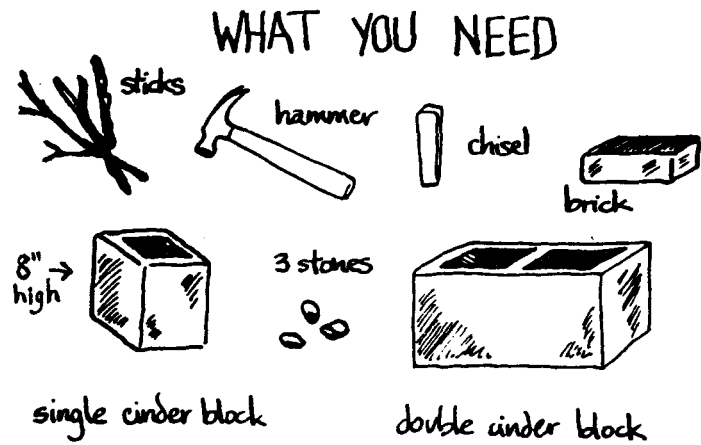

chip out $\frac{2}{3}$ of the divider

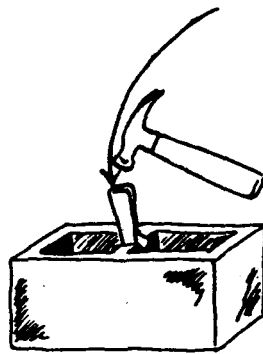

A rocket stove built from cement blocks: The stove can be placed inside of any kind of a form. Insulation can then fill the space between the stove and container, which helps the stove to burn hotter and smoke less.

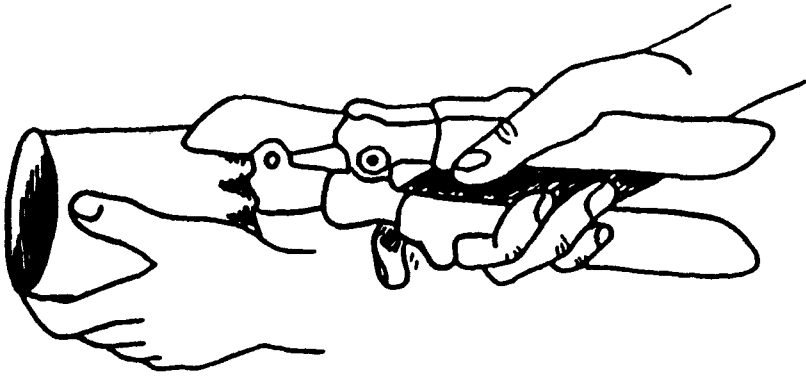

CRIMPING THE TIN CAN

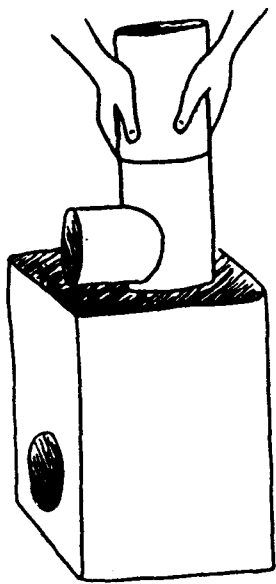
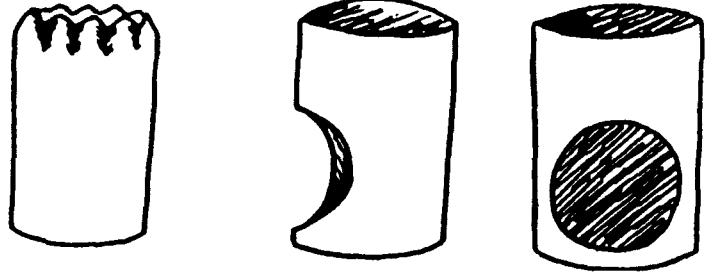

INSERTING THE FIREBOX AND CHIMNEY INTO THE EXTERNAL BODY OF THE STOVE

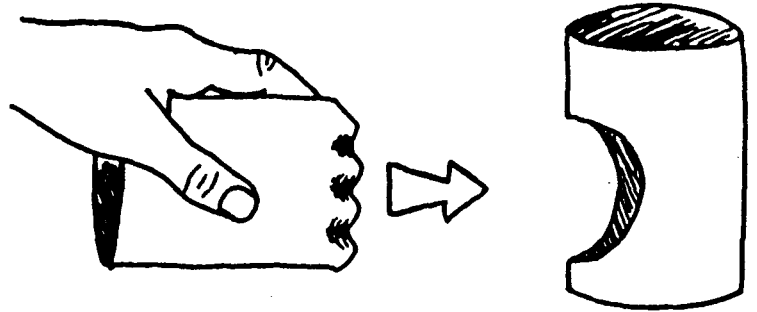

MAKING THE FIREBOX AND CHIMNEY

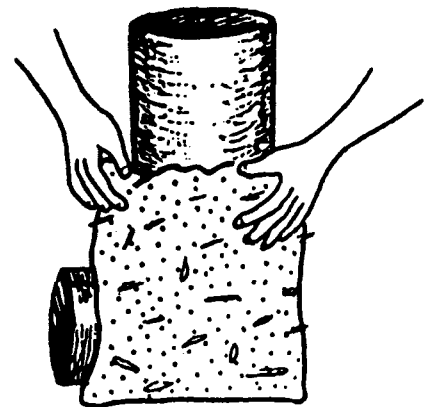

OPTIONAL USE OF CLAY/SAND

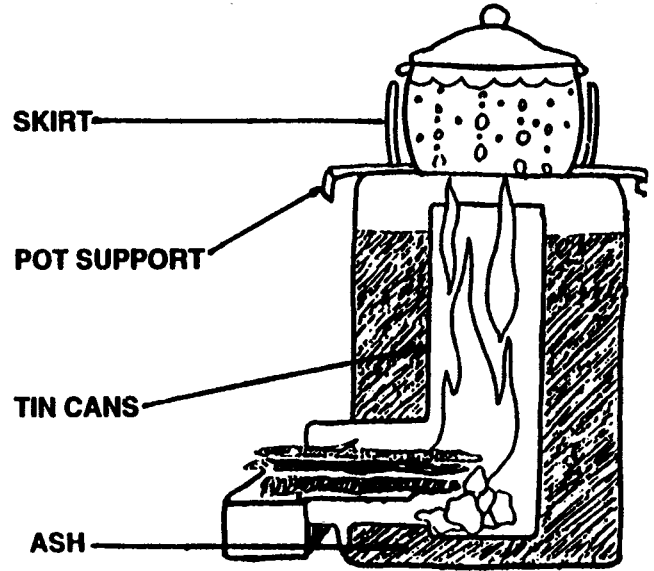
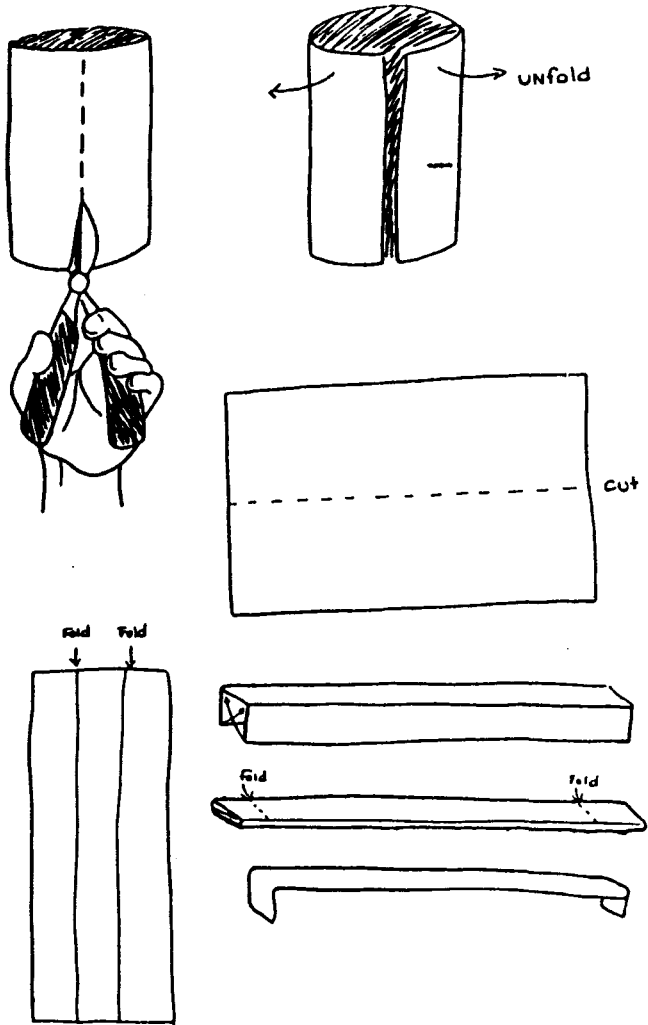

SKIRT
 POT SUPPORT
 TIN CANS
 ASH

STOVE WITH POT SUPPORT AND SKIRT

MAKING THE POT SUPPORT

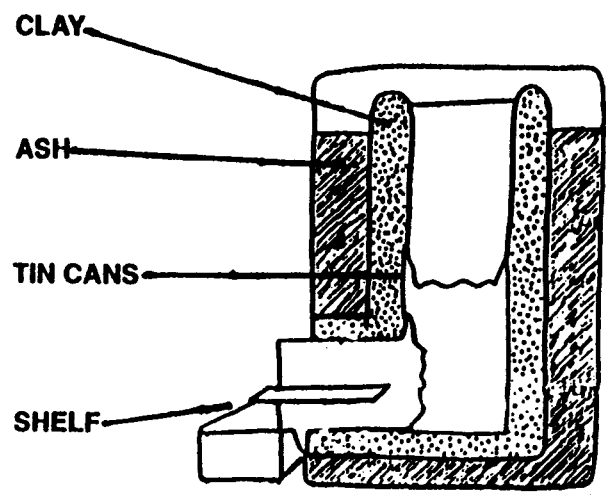

CLAY
 ASH
 TIN CANS
 SHELF

THE STOVE WITH CLAY/SAND AROUND THE TIN CANS

Mass and insulation, when combined, make for a perfectly lovely, easily heated solar home, or an effective stove. However, when mass is wrongly used, or is thought to be like insulation, mistakes in construction are made. An understanding of these two factors can help us all in our search for a bountiful, not sparse, simplicity.

Concerning Stove Efficiency

When Dr. Winiarski and I first walked around San Nicolas, the ranch in Mexico where I have a house, he surprised me by saying that the Rocket stove wouldn't save a tremendous amount of firewood. He saw how well the ranchers made fires and thought that a fuel efficient stove would save only 30% to 40% more firewood.

When people are careful and expert, the indoor open fire (or three stone fire, as it's sometimes called) is a relatively efficient cooking method.

Traditional methods can work very well. In fact, the indoor, open fire can be more efficient than higher mass, supposedly fuel efficient stoves. Of course, this probably plays a part in the cultural resistance to new methods of cooking. The introduced methods are not necessarily superior in every way.

God made fire, people made pots. The trick in improving efficiency is not so much to improve the efficiency of combustion, but to improve the transfer of heat into the pot. The skirt around the pot is very important. The stove body keeps wind away from the fire, keeping the fire hot enough for more complete combustion to occur. The stove "forces" users to feed wood more slowly, to make better fires. It can be tempting to build an overly large open fire, since a large fire won't go out as easily.

Fuel efficient stoves can save a lot of fuel

compared to open fires outside in the wind. They can play a very important part in decreasing the need for large amounts of firewood for cooking.

However, an indoor, open fire is not necessarily an inefficient cooking method. It takes a low mass stove with a skirt to improve upon it. A high mass stove can easily use more fuel than a simple indoor fire, especially when the stove isn't in constant use, which is frequently the case. It really all depends on how carefully people make fires.

How to Make a Rocket Stove with Tin Cans

In many countries around the world it is advantageous to use tin cans to make a chimney. Tin cans are often available when there is no other chimney material. The cans will burn out in about a month. However, it's possible to replace the cans rather easily. (Of course, it's always possible to make a fired clay chimney and firebox, that will last much longer.)

You'll notice from the diagram that it is possible to cover the chimney with a mixture of clay and sand (60% sand mixed with 40% clay works well). When the tin can chimney burns out, the sand /clay chimney takes its place. The ash insulation, of course, is still used between the outside of the clay/sand chimney and the metal stove body.

In Zaire, many Rocket stoves were built for and by Rwandan refugees using the containers that had held relief supplies. The container was cut up to make the chimney and firebox. Pumice rock or wood ash filled the interior of the stove between the external body of the stove and the chimney. It is even possible to make the external stove body out of sand and clay as long as insulation surrounds the internal chimney. A chimney really helps to burn up smoke, to keep the fire going, and to direct flame at the pot.

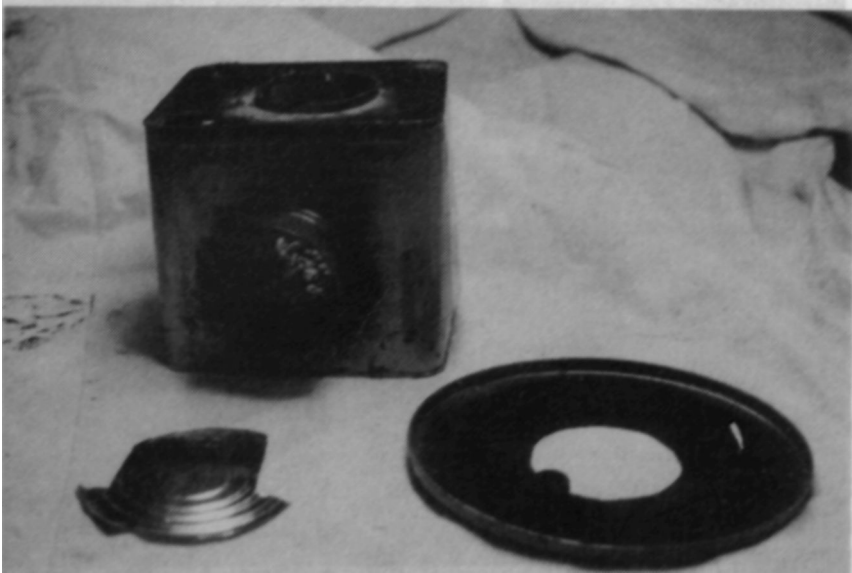

*The stove body, shelf,
and skirt support.*

*The shelf is inserted
into the firebox.*

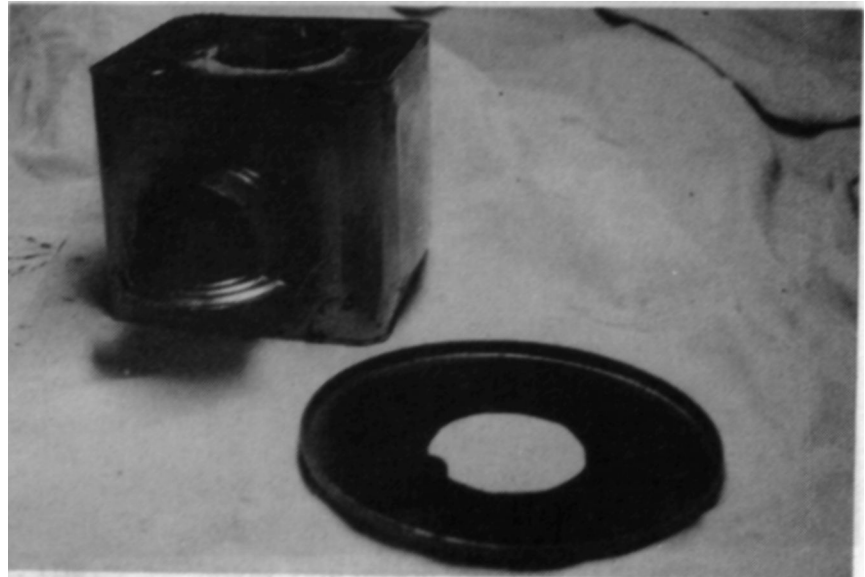

*The skirt support rests
on top of the stove body.
The skirt is also shown.*

*Three pot supports
an inch long sit on
the skirt support.*

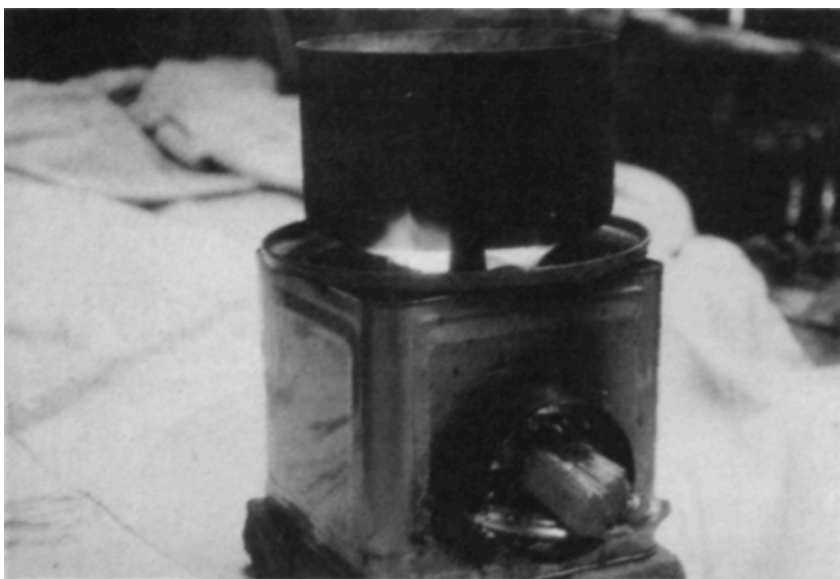

*The pot rests on
the pot supports.*

*The skirt directs the
heat around the pot.*



Hayboxes (Insulated Cookers)

When the sun isn't shining and people are cooking with wood, a lot of energy can be saved by using a haybox. (Hayboxes are sometimes called fireless cookers.) After boiling the food for a few minutes, the hot pot is placed inside an insulated box, where it finishes cooking. The retained heat is enough to simmer the food to completion. A haybox does all of the simmering for us, saving not only energy but effort as well. Saving the firewood that wastefully went into simmering the food results in tremendous savings!

A haybox also makes cooking much easier. No more dealing with watched pots to guard against boiling over or scorching. At Aprovecho, we usually make lunch while getting breakfast. All we do is quickly boil up the beans and rice and then pop them into hayboxes where they'll emerge hot and ready for lunch. It saves a lot of time and effort.

Hayboxes have been used for centuries in different countries.

They work by keeping food hot enough (over 180 F.) for cooking to continue. The design criteria are simple:

Make sure that there is plenty of insulation around the pot, especially the bottom and top.

The pot should fit into the box as snugly as possible.

The lid on the haybox should make a good, airtight seal.

A wide variety of materials, besides hay, can be used for insulation. Remember that any material that traps isolated pockets of air will insulate well. Examples of insulation are: straw, rushes, chaff, popped grain, wood

shavings, sawdust, newspaper, fiberglass, feathers, cotton, sponge, fur, wood ash, charcoal, etc. If you use one of these, allow 4" of wall thickness. If you use cork, cardboard, aluminum foil, styrofoam, rigid foam, etc. you can reduce the thickness to two inches.

One of the most efficient hayboxes is made by filling the air space around the pot with cushions, held in place inside a box.

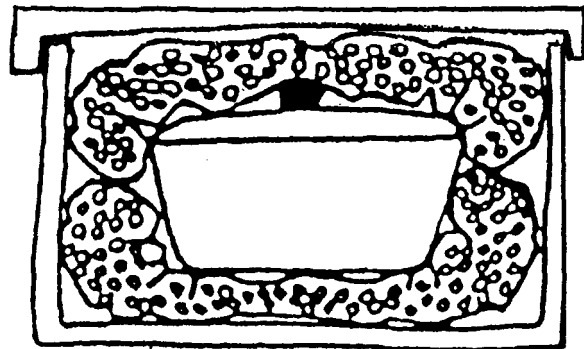

Fill the space around the pot with cushions.

Another simple method is made from two boxes, one inside the other. The space between the two boxes is filled with insulation. An insulated lid or cushion fits over the top.

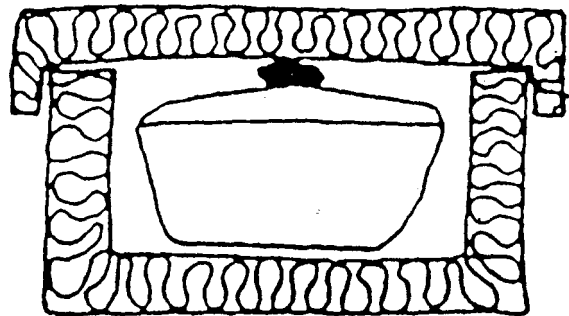

Two boxes with insulation between them.

Or we can invert the box and have it sit upon an insulated base on which the pot also rests. Raising the pot up onto another higher platform, like a piece of plywood, makes a double seal to keep air from escaping.

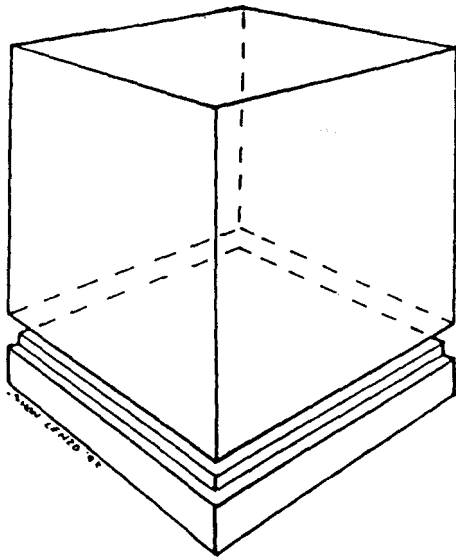

An insulated box resting on a platform.

Another type of haybox is made from a double bag of material lined with insulation. A draw string closes the top. The neck of the bag should open wide so that the pot can enter and be withdrawn easily.

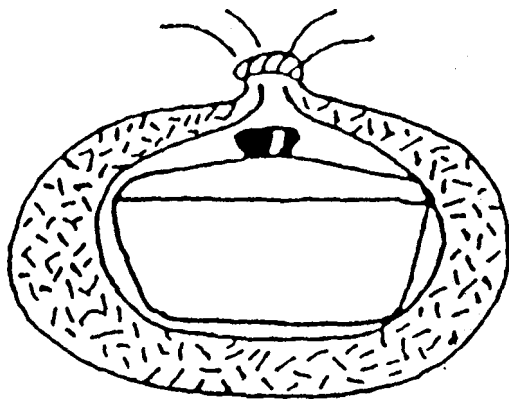

A double bag lined with insulation.

A haybox can be something very simple, like a hole in the ground that is filled with hay, straw, etc. The pot is placed inside the hole and covered by thick layers of insulation. The hole could also be made in a block of sand/clay mixture above ground so as to be more easily reached.

Simmering food in a haybox will take about one and one-half to three times longer to cook than on a cooking stove. A large mass of food works better than smaller amounts. A tight lid on the pot helps as well. Using one quarter less water with grains is better since less water is lost to evaporation. It's possible to wrap the pot in a towel before putting it in the haybox.

Bacterial poisoning can be avoided by two simple steps. Make sure that the food is initially boiled for at least 5 minutes. Then keep the lid closed from that point on and reboil meat dishes before serving.

We can't imagine cooking now without hayboxes. They're truly one of those rare devices that save energy and make life simpler at the same time! We've used them for more than ten years and highly recommend them. Hayboxes are so fuel efficient, because the haybox does all of the simmering "for free", without using energy that would have mostly gone into making steam, anyway. The Rocket stove/haybox combination is capable of cooking with very small amounts of biomass. And, this method is easier, safer, and more convenient!

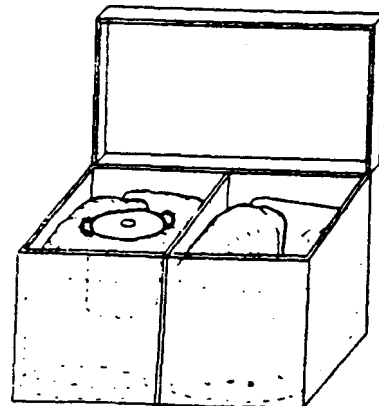

The Rocket Bread Oven

Dr. Winiarski and I built this very efficient oven in 1990. It is used about once a week at the Research Center for baking bread, etc. It can hold more than 20 loaves. Sixty-six pounds of bread can be completely cooked using 11 pounds of dry wood.

The oven is built out of 55 gallon drums and can be made inexpensively.

The oven can be built in different ways. One method uses two drums. The inner drum holds the bread. It is completely closed except for three doors cut into the front of the barrel. Six layers of aluminum foil, each separated by a small air space, insulate between the two barrels. (We've also built bread ovens without aluminum foil. Instead a third barrel surrounds the second. Insulation fills a 4" gap between the 2nd and 3rd barrels.) A gap of about an inch, between the inner barrel and the foil, allows the hot flue gases to rise up between the two barrels. In effect this gap becomes a part of the chimney.

Many elements act together to make this an effi-

cient oven:

The hot air is in contact with the bottom, the sides, and the top of the inner drum which contains the bread.

The hot air is forced through a tight gap that forces the heat to touch the inner drum, heating it more efficiently than would happen if the gap were wider.

The inner drum is low mass and is insulated by the aluminum foil that creates air gaps between each layer. (Aluminum foil also reflects infrared radiation back into the inner drum, at the bread.)

The insulated firebox keeps the fire hot, assisting complete combustion and reducing smoke.

The insulated chimney creates a great deal of draft and air is pre-heated before it can cool the fire.

The fuel is either fed vertically or horizontally. Vertical feed allows for more preheating of air and the wood is more self-feeding. Horizontal feed is more what people are used to, and

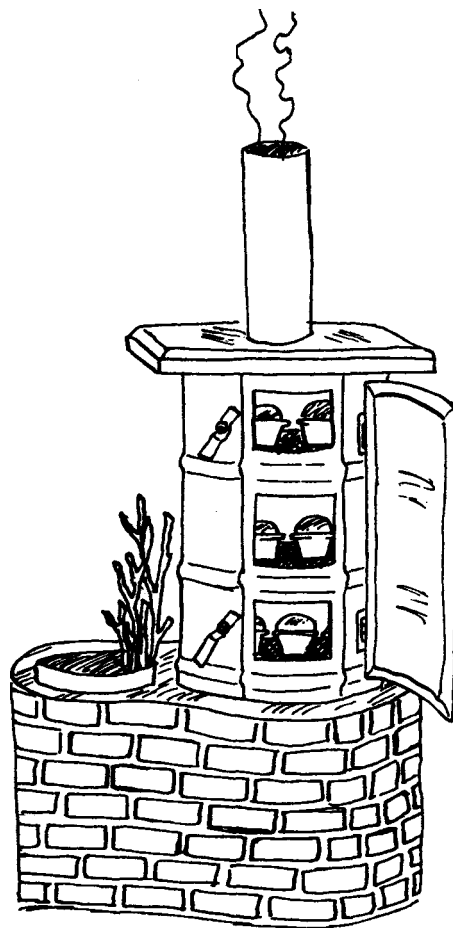

The downfeed-downdraft bread oven.

doesn't suffer from backdrafting as much. Horizontal feed is only slightly less efficient.

The fire chamber and fuel magazine can be formed in various ways. (Please refer to the drawings.) The oven at the Research Center uses a 14 gallon drum as the feed box. It has a fired clay liner inside it, surrounded by pumice rock as the insulation. This liner creates the fire chamber and tunnel that directs the fire at the bottom of the inner drum. (It's also possible to make a horizontal fire box patterned after the smaller Rocket cooking stove.)

A metal cap, also insulated, covers both barrels and sits 1" above the inner drum, allowing the flue gases to reach the chimney unimpeded. A six inch in diameter section of chimney pipe exits vertically from the cap.

Three shelves fit into the rings of the barrel. We cut circular shelves out of metal fencing to be a bit bigger than the diameter of the drum. These shelves were forced down into the barrel, to spring flat and find support in the rings.

The doors were cut as cleanly as possible. A large door, covering all three holes, swings on hinges attached to the outer barrel. It closes against two pieces of angle iron that fill the gap between the two barrels.

This oven saves a great deal of fuel when compared to a beehive earthen oven. People cannot believe that a few sticks can be heating the entire interior of the drum to cooking temperatures.

In Mexico, it's been the design most universally praised. It's easy, with a bit of practice, to regulate the temperature, and large amounts of food can be made at one time. We recommend it very highly!

Earthen stoves can use so much wood, to bake so little bread! At the very least, earthen stoves can be covered by insulation (wood ash, etc.) so that the heat isn't as easily lost. The low mass oven heats to 350 degrees F. in twenty minutes and keeps at that temperature with small branches added to the fire.

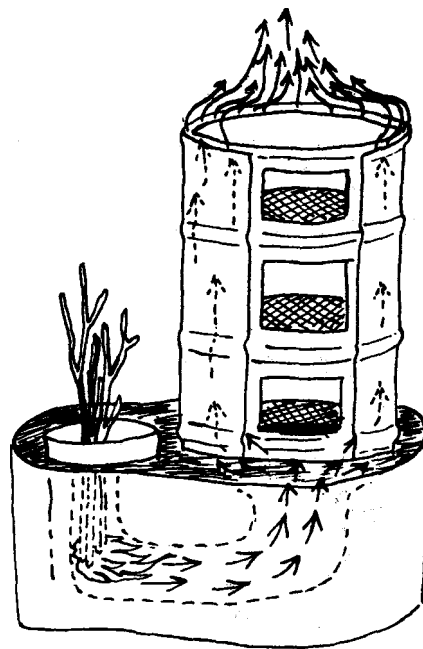
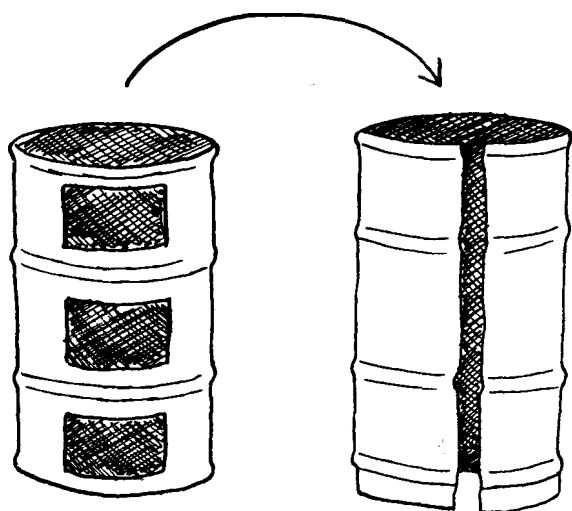

The split drum slides over the inner barrel. How flue gases pass between the drums.

How to Construct a Winiarski Rocket Oven

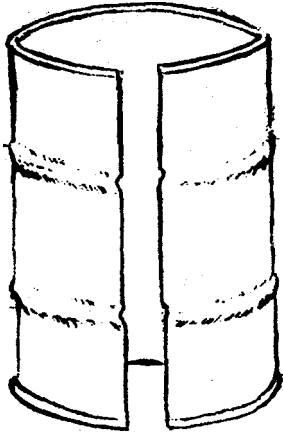

Cut three door openings in a 55 gallon drum. Leave the top and bottom on the drum.

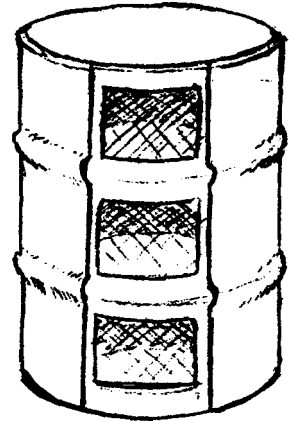
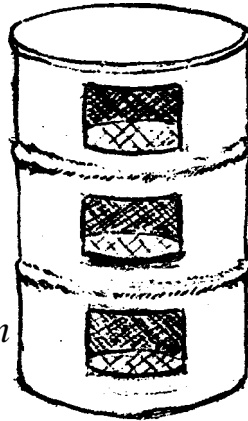

Gut the top and bottom out of a 55 gallon drum. Split the drum longitudinally.

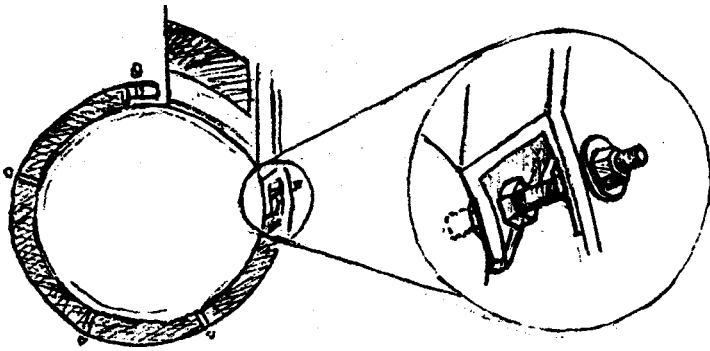

Slide the split barrel over the barrel with the door openings.

The oven can be placed on top of a ring of bricks.

A gap of one inch is created between the first and second drum. Bolts hold the drums in this position.

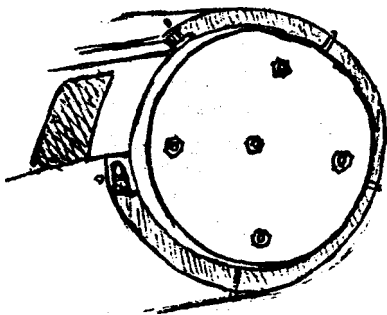

A sacrificial plate can be bolted to the bottom of the inner drum, protecting it from prolonged exposure to the flame.

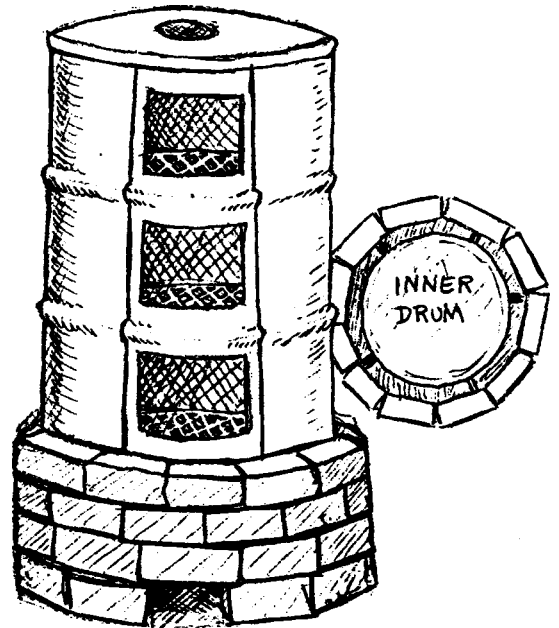

The gap between the inner and outer drum is not blocked by this ring. The outermost drum rests on the inner edge of the brick wall.

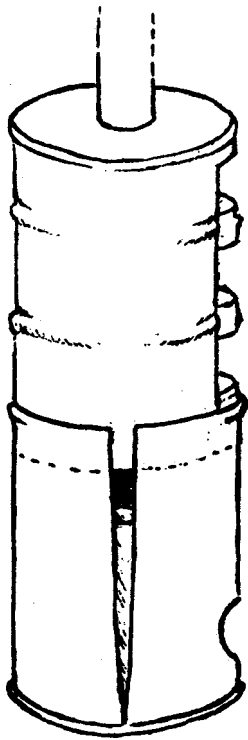

Split the third drum longitudinally. Cut an 8 inch in diameter hole in the bottom of the drum.

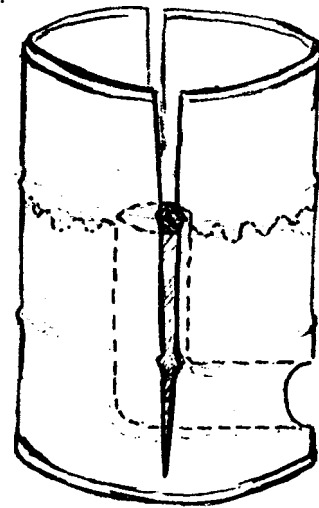
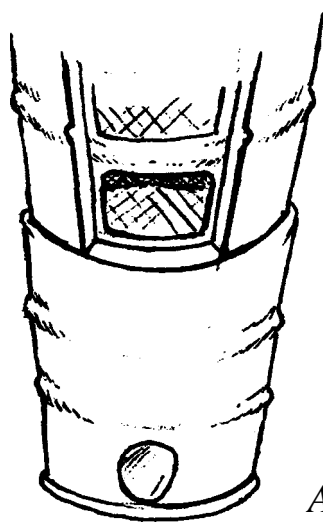

An elbow of stovepipe fits into the 8 inch hole. The stovepipe ends 2 inches below the oven. The space between the stovepipe and the inner wall of the third barrel is filled with insulation, such as wood ash.

It's also possible to make the firebox for the oven out of a third 55 gallon drum.

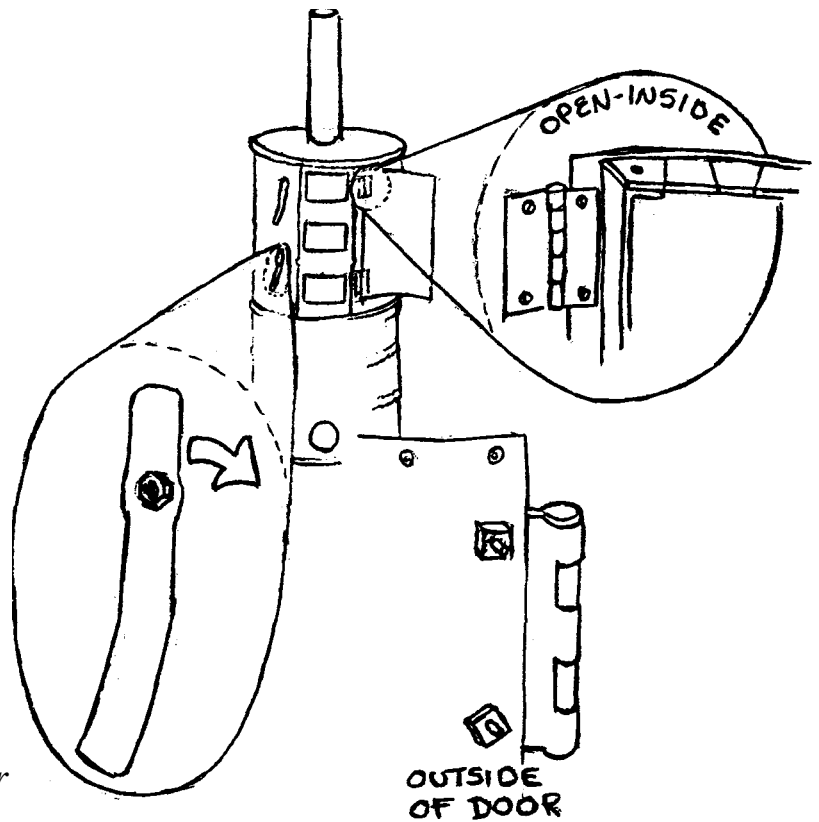

A covering of sheet metal is screwed over the openings in the bottom barrel.

This diagram shows construction details of the door which covers all three openings in the bread oven.

Visit the Research Center

Please visit Aprovecho whenever you're in Oregon! We have a self guided tour through both the campus, garden, and forest. Just call for directions...

Aprovecho is a non-profit, membership supported organization. Membership dues are \$30 per year which includes a newsletter, News From Aprovecho, detailing results of current research.

The cost of the ten week internship is \$1,830 per semester which includes room and board in the straw bale dormitory. Please make arrangements early since the internship tends to fill a semester in advance.

Capturing Heat: An Appropriate Technology Design Manual will be available in September of 1999. It is a more complete version of this booklet and includes: how to heat water and houses with both direct and indirect (stored) solar energy, simple refrigeration, composting toilets that work!, desalination and drying designs, etc. Please contact us for details.

The following designs are included in the larger Capturing Heat:

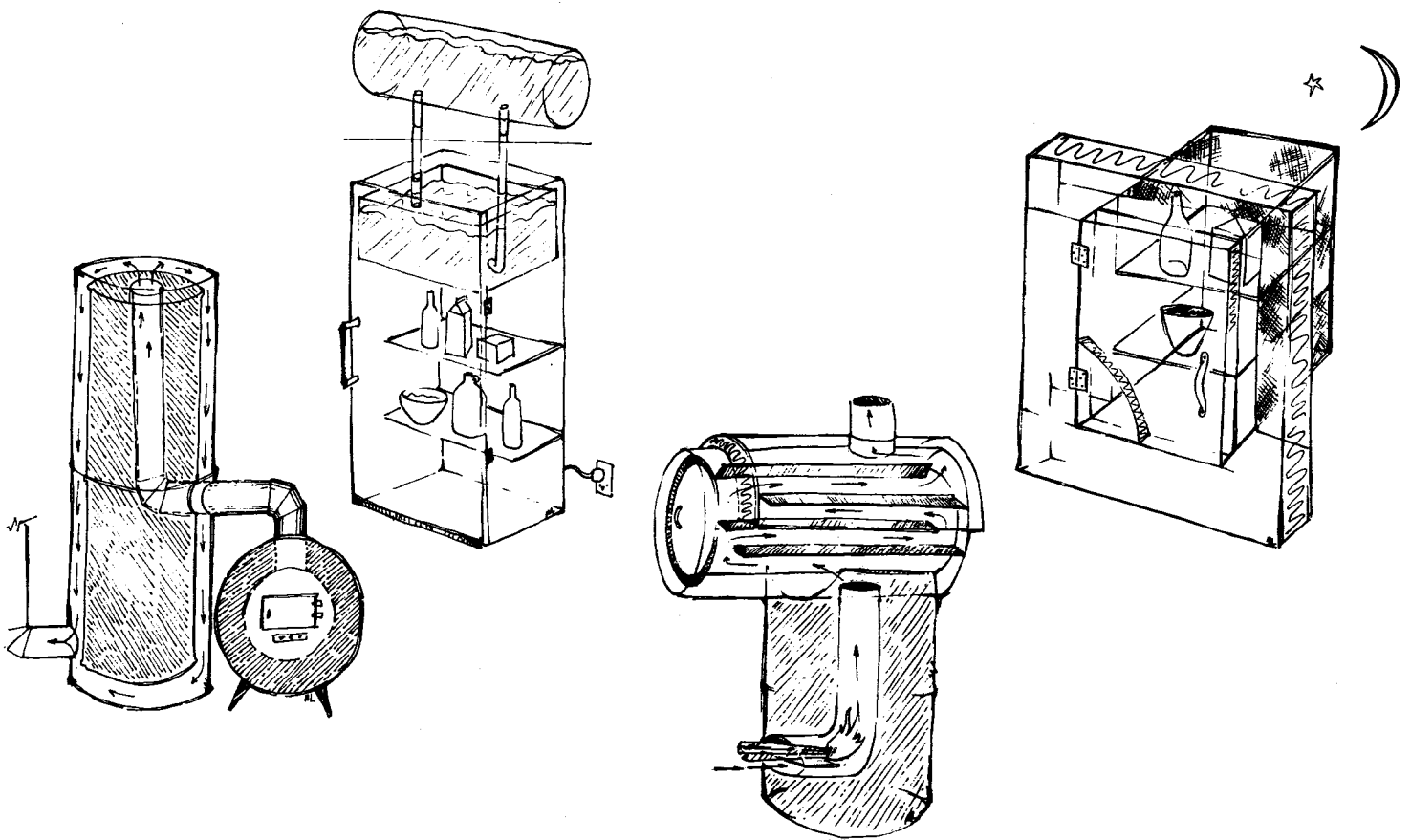

Aprovecho is a non-profit, membership supported organization. Dues are \$30 a year and include a newsletter detailing results of current research.

*We also offer a 3 month **internship program** for people who want to learn about organic gardening, sustainable forestry and appropriate technology. The cost is \$500 per month which includes instruction, room and board. Sessions begin March 1, June 1, and September 1 in Oregon. We also offer a one-month January session in Mexico. Classes include lectures, discussion, practical work, and field trips, and run 8-5 Monday through Friday. Please contact us for complete information.*

*Our phone number is **(541) 942-8198**; fax (541) 942-0302. Please call in advance of your visit. If you would like written information, please send a SASE to **Aprovecho Research Center, 80574 Hazelton Road, Cottage Grove, Oregon 97424.***