

How To

FUEL YOUR CAR

&

HEAT YOUR HOME

During the Hard-Times



1.

This remarkable report has been designed to enable the average person to manufacture his own fuel, cheaply and easily. After thoroughly researching this report, we did our very best to reduce language that is usually heard in chemistry and physics classrooms into common terms. The primary objective of this report is to provide the reader with the necessary knowledge needed to make his own fuel without complications.

While fuel shortages continue to prevail, reports are constantly coming in from various countries throughout the world of alternate sources of energy. From inside of our own country, farmers, homemakers, even city and town governments are resorting to the use of ethanol in trucks and cars as an alternate source of fuel with remarkable results. The drivers of these vehicles reported that they experienced faster acceleration, smoother idle, higher octane and better mileage.

Brazil has been using ethanol for years and current reports state that more and more drivers are enjoying cleaner burning engines.

The myth that an automobile can only run on low lead or a high octane petroleum product is just that, a myth. Ethanol is a much better product than gasoline because it burns much, much cleaner. As a matter of fact, if you were to start using your own homemade fuel, you would discover in time that your engine would be practically free of carbon and other chemical residues that normally build up in a gasoline fueled engine.

There are other advantages to making your own fuel. Besides extending the life of your engine, ethanol fuel:

- *gives better mileage
- *costs much, much less
- *promotes a cleaner running engine
- *provides faster acceleration,

and as a result:

- *you need never wait on a gas line
- *you need never run out of fuel.

The average motorist "fills-up" approximately once a week with about 20 gallons of fuel. This averages out to over 1000 gallons per year. Based on the present \$1.25 per gallon average, the cost to the average motorist is \$1,250.00 per year. There is every indication that the price of gasoline will rise steadily until it is comparable to the cost of fuel in Europe and Asia which is presently between \$3.50 and \$6.00 per gallon.

For those who will still be in a position to use their vehicles and pay this exorbitant price, the cost will be over \$3,000.00 per year !

If, on the other hand, you have taken the time to study and utilize the material presented in this report, you shall find yourself in the enviable position of having all the fuel you need at a cost of approximately 16¢ per gallon. As you read through this report, you will realize that we have so simplified the process that almost anyone can do it.

At this point, let us make a suggestion. Take a 10 minute break, maybe have a cup of coffee. It will help you to relax so that you will be able to read through the balance of this report without interruption.

THE MAKING OF ETHANOL, An Alternate Fuel

Step I

In order to understand fully the process employed to make one's own fuel, we will divide the process into two steps. The first step is known as mashing. During this phase of our preparation, we are fermenting some organic matter into a substance commonly termed MASH. Some organic materials are better suited for fermentation than others. Corn, wheat, most fruit (spoiled), potatoes, sugar beets, molasses, and even wood chips can and have been used.

However, for our project, we chose corn because it is fairly inexpensive and there is plenty of it to be found. Farmers who use corn to make their own fuel, also utilize the left-over residue as a source of animal feed which is high in nutrients. Others accumulate this left-over material and then sell it to people who have livestock.

During the fermentation process, carbon dioxide gas and alcohol are produced. When your mash solution is ready to be fed into the distiller (in the second phase of our project), it is approximately 25 proof. After this solution is fed into the distiller, alcohol vapors are cooked out of the liquid mash solution, and are condensed into a much purer form of alcohol. This is the process of distillation.

At this point, it is reasonably understood that our first step in making our own fuel is making mash. We shall now proceed, step by step, to prepare our own mash solution by listing the needed materials and discussing their uses. As mentioned earlier, we will use corn because it is relatively inexpensive and plentiful. There are several kinds of corn which one can use, sprouted corn, whole kernel corn or ground corn meal. We will use coarsely ground corn meal.

The exact recipe (and procedure) is as follows:

(You will need-)

- 25 lbs. coarsely ground corn meal
- 5 lbs. cane sugar
- 1/2 lb. Baker's yeast
- 50 gallons of water (80° F.)
- 55 gallon wooden barrel (plastic will do) with cover
- 4 feet of 1/4" hose with an adapter
 - (a hole must be made into the cover of the barrel to exhaust the carbon dioxide gas as your mash solution ferments)
- A good sealant (to seal the solution tightly into the barrel and prevent air from getting into it).

Pour 50 gallons of water (80° F) into the wooden barrel or plastic container. Water can be taken right out of the hot water faucet. The correct temperature is imperative and one must not be flexible regarding it. Use a thermometer to deter-

mine the proper temperature (80° F). A word of caution at this point. Nothing can prove to be more devastating than using an unclean barrel or container. Make sure that the barrel or container is clean. This is best done by scrubbing with a mild bleach and water solution. Place the 25 lbs. of coarsely ground corn meal into the water and after breaking the 1/2 lb. of Baker's yeast into small pieces, drop them into the solution. Then, add the 5 lbs. of sugar and stir lightly.

The moment the mash solution is inside your barrel, cover it carefully. Remember, a hole of approximately 1/4" must be drilled into the cover of the barrel or plastic container.

Now with the aid of an adapter, attach the 4 foot length of hose to the cover. Any local hardware store or plumbing supply house carries such adapters. As you now know, this hose will serve as an exhaust for the CO₂ discharged as fermentation takes place. The discharged gas will also tell you when the mash solution is ready to be strained.

Let us caution you again at this point. Once you have made your mash solution and covered it, DO NOT move or disturb the container. The process of fermentation will take place automatically as long as the temperature of the area in which the container is stored is between 70° and 90°. Be sure that the container is tightly sealed. Use a sealing compound around the hole in which the adapter was placed. Place the extended tube into a pot of water so that the discharged gas will form bubbles in the water and prevent air from leaking into the MASH.

Pay close attention to the hose in the water. You will observe bubbles as your mash solution "cooks". In about 3 days or so, you will notice all the bubbles have ceased to form. DO NOT uncover the container until you are sure that the solution is finished "cooking".

You can now open and strain the contents through a filter or clean burlap strainer. The filtered liquid mash solution is then fed into your distiller.

The final stage is quite simple.

BUILDING YOUR OWN SOLAR STILL

Step II

The second phase of making your own fuel is feeding the filtered solution into a Solar Distiller (the process of distillation).

The use of the sun's energy to operate our distiller has many advantages. The chief one, of course, is that you don't have to use energy in the form of electricity, gas or wood in order to produce liquid energy. We feel that this would be self-defeating, since the cost would be prohibitive.

Some individuals may erroneously believe that there is not adequate sun all year round to make this approach practical. You do not need sun year round.

The truth of the matter is that with very little effort one can easily accumulate all of the ethanol needed for a year in two or three weeks of solar still distillation. Of course, this is providing that one has built a compact still and the right size to suit his needs.

Once inside this boiler (actually, that's what a distiller is), the mash solution is cooked or heated up (in our case by solar energy). Alcohol vapors will rise out of the solution and run down the sides of the glass into a trough. Once in the trough, the alcohol will run out into a large retrieving container. It is quite easy to build this solar still. It does not require any fancy carpentry work. The solar still(boiler) is best described as a cabinet with a glass front and enough space on bottom to contain your mash solution. The solar cabinet can be as small or as large as you desire depending on how much ethanol fuel you require. You can begin by building a small solar still so that you can familiarize yourself with its "workings". Then later, you can build a larger one, as your needs dictate.

Now one can readily understand the principle upon which a solar still operates

The sun is used to vaporize the strained liquid mash solution which is enclosed within the sealed solar cabinet. As the vapors from the liquid mash solution rise, they strike the inside of the glass of the solar distiller. The glass is naturally cooler than the bottom of the distiller. You see, the glass will allow the short wave lengths of the sun's ultra-violet rays to enter thru the glass, but will not allow the long wave lengths of the produced heat to exit back out. We have created a condition whereby heat is imprisoned within the solar cabinet.

As the vapors from the mash rise and strike the cooler surface of the glass, they condense. The angle of your glass will cause the condensed alcohol to run down to the bottom where it is caught in a simple metal trough. From this trough, your purer form of liquid alcohol runs into a storage container.

At this point, one could understand fully the way that the solar still condenser operates. Of course, one must keep in mind at all times during the building of a solar still that it must be very compact and tightly insulated. Also, as you probably know, it must be painted black inside because black absorbs more heat from the sun than other colors. Remember, that the greater the efficiency of the still, the hotter it is within. Therefore, one must take every precaution to make certain that the inside of the constructed solar still is properly coated black. Use a good grade of marine oil base paint, several coats for best results. Also, when installing the glass, use a good adhesive sealant to assure a tight seal so as to prevent any heat leakage.

THE COST

The cost involved in producing a gallon of ethanol will vary with the ingredients that are used in your mash solution. Mash can be made from corn, wheat, wood chips, spoiled fruit, sawdust, weeds, grass cuttings, even roots.

You can pickup spoiled fruit from any fruit store or a market free. As a matter of fact, many grocers will be glad to give it to you. Grass cuttings and weeds, even wood chips are easily obtained for next to nothing, thereby reducing

your cost to just pennies per gallon.

In the April 25th issue of the South African Digest, a full length feature article appeared with pictures illustrating, in great detail, how the South African government is producing ethanol with the cassava root. The CED, the Corporation for Economic Development, is sponsoring a program to provide raw materials(the cassava plant) for ethanol and stockfeed. Mr. Koos Richards, the gentleman in charge of the project, explained that an adult cassava plant could yield 18,000 offspring, each of which yields heavy roots suitable for ethanol production. It was further stated that the natives use the cassava plant for many things. The leaves are used as spinach, its roots for making porridge, bread, beer, and starchy meal that is mixed with beans. Cassava crops are very rich in carbohydrates.

The cassava plant, like many, many others are ideal for making mash. With a little ingenuity there is no doubt that ethanol can be produced by a solar still for next to nothing.

In the pages that follow, you will find diagrams of the mashing container and the solar still, in detail. You can follow the same proportions or scale down to smaller or up to larger sizes as the need may present itself. The materials listed have proved to be most successful. This does not mean that other substitutes cannot be used providing they will perform a like function in a similar satisfactory manner. Remember, the main objective is to get the maximum alcohol out of the mash solution, by volume.

PROCEDURES

MASH CONTAINER

Figure 1. is an illustration of a typical setup used in "mashing"(see Step I, the making of ethanol). A 55 gallon barrel type drum of wood using a heavy plastic liner is preferred. Although, any good clean container can be used(re-read the caution notes in Step I regarding unclean containers). It can be square, round,

oval or oblong. Shape does not really matter so long as the cover is tightly sealed and has a sealed vent adapter with a length of hose extended into a small container of water.

Again let us stress the importance of cleanliness inside the container and that once the mash is placed inside the fermentation container — the container must be sealed tightly and not moved.

BUILDING YOUR SOLAR STILL

Start with a piece of plywood that measures 4 feet wide by 8 feet long and 1/2 inch thick (4'x8'x1/2"). To this, nail pieces of 1"x4" wood so as to give the solar still a top, bottom, and sides (commonly known as "boxing in"), see Figure 2. Also, nail a center 1"x4" support into position. This is to support the glass which will be installed (two 4' x 4' double or single strength pieces cut to fit). Now, nail or screw glass molding around the outside edge of the boxed frame, overlapping approximately 7/8". 1"x 2" wood molding (or strips) is suggested. Drill a hole in the upper left side of the frame to accommodate a 1/2 pipe or tube (plastic is fine). This feed-pipe must be drilled with 3/16" holes 1 1/2" apart. It is through this tube that your mash solution will ooze out, slowly, and drip onto the burlap that is to be tacked onto the backboard (the 4' x 8' plywood). The entire exterior (or interior) of the cabinet must be lined with styrofoam for insulation. Common shutoff valves should be installed on both sides (at the bottom) of the solar distillery for drainage and cleaning purposes.

Next, take some metal flashing and bend slightly into a "U" shape with a lip and place it in the bottom of the unit. Solder metal ends and right-angle supports for the glass to the flashing. The metal ends are nailed or screwed to the side and center sections. In the center of each of these "U" shaped metal sections, drill a 1/4" hole for the alcohol to run out into a retrieving

container. You will need two 6" lengths of copper tubing. Solder these into the drilled holes. Make certain that the burlap is dyed black and that the entire interior of the distiller is painted black so as to properly seal the wood (several coats with a good marine paint). It would also help to paint the exterior.

Now, place the glass in position (seated against 1" x 4" framing on sides, top, and center and into the metal flashing on the bottom) and seal in with glass caulking compound or a press-type permagum cord sealer. Using the latter, permits easy removal of the glass, if necessary.

Place your unit at a 45° angle facing the sun and place it up above the ground for maximum heat, see Figure 3. Both the solar distillery and the mash liquid tank should be mounted on separate stands, but this is not necessary (your own method will do).

HOW TO TEST FOR PROOF

When you retrieve your alcohol from your solar distiller, you will want to know its proof. Since water is much heavier than alcohol, one can arrive at the proof by specific gravity. The measuring device used for such purposes is known as a hydrometer. You may obtain one in any wine shop for a few dollars. Alcohol "proof" gallons simply means 50% water and 50% alcohol (100% proof by volume). For purposes of operating a combustion engine, alcohol at a proof of 160 or higher is ideal.

FINAL NOTES

Carburetor Adjustment

In most cases, it is advisable to mill out the carburetor jets to a slightly larger opening. This, of course, depends upon the year and make of the car and the kind of carburetor that it has. It is a very inexpensive process and any

reliable service station is able to take care of it for a small cost.

How Much Ethanol From 55 Gallon Drum of Mash Liquid

This depends a great deal upon the efficiency of your distiller and the material that you use for mashing. However, realistically, you should retrieve between 13 to 20 gallons of 160 to 175 proof of ethanol. Remember, one of the best, fastest, and cheapest ways to make a high grade ethanol is with spoiled fruit. Large quantities of spoiled fruit are available just for the asking. Just remember, if you are making mash from fruit no sugar is necessary, only yeast.

A FINAL WORD OF CAUTION

To make alcohol without permission can be a very costly and illegal experience. The manufacturing of alcohol is regulated by the Bureau of Alcohol, Tobacco, and Firearms. You will find this department very cooperative, once you have explained why you want to make alcohol.

Agents from this bureau will explain to you how to denature your alcohol by using an additive. In this way, they will be assured that you will not use the alcohol for human consumption.

Enclosed herewith you will find two application forms to help you get started.

BEST OF LUCK !

THE SECRET OF MAKING LOW COST FUEL

For maximum economy, use whole kernel corn. Whether you buy it or raise your own, milling expense is eliminated. More important, the intact seeds can be malted (made to sprout), which "frees" their sugar content and vastly reduces the amount of "outside" sugar required for fermentation. Indeed, many fuel makers, once they master the malting process, reportedly add no extra sugar. Initially, add the small amount indicated, as "insurance."

Before malting or preparing mash, your mash barrel and malting trays must be clean. Scrub 'em down with a solution of one part household bleach to ten parts water, to discourage outside bacteria. The only bacterial action you want is yeast acting upon sugar.

To malt corn, place a single layer of kernels, spaced closely, in wood or plastic trays. Add enough warm tap water to thoroughly wet seeds. Let trays sit, uncovered, in a dark warm place for 24 hours. Then drain-off water and "sandwich" kernels between damp rags or burlap.

The idea is to keep seeds moist but not wet enough to cause water rot. Rinse kernels every 12 hours or so to wash-off any forming mould, then return them to the burlap. In about 48 hours you'll have tendrils 1/4 to 1/2 inch long. Your corn has malted.

Set mash barrel in a warm place 72 degrees-90 degrees F. Pour 20 gallons of warm water, about 80 degrees F., into barrel. Add 10 lbs. of malted corn and just over 3 ounces (3.2) of finely-crumbled baker's yeast, which you can get at a bakery. (Do not use the active dry yeast sold at grocery stores) Next, add a 1/2 lb. of cane sugar. Mix ingredients thoroughly, then cap and seal mash barrel. (For a 50 gallon batch, you'd use 25 lbs. of malted corn, 1 1/4 lbs. of sugar, and 8 ounces of yeast. For 100 gallons, double these quantities.)

In three to four days fermentation will be complete with alcohol content from 12 to 14 percent. You're ready to start the distilling process.

WHAT WILL YOU USE FOR A MASH BARREL?

Eventually, considering that you get from 2 1/2 to 3 gallons of alky from 50 gallons of mash (containing 25 lbs. of corn), you'll probably want to move-up to the traditional moonshiner's 55 gallon drum. Two runs a week should take care of all or most of your driving needs.

During your experimental phase, you'll probably want to work with a smaller container. A good bet is a 20 gallon "recycled" steel drum, or plastic garbage can. Either is easy to find, quickly modified to your needs, and can do double duty: (1.) As a mash barrel for fermentation; (2.) To hold the distilled juice while it drips into your still.

Any mash barrel needs an escape valve for the carbon dioxide that forms during fermentation. You make this by drilling a 3/8" hole in the lid or cover, and inserting a 3" length of 3/8" O.D. copper tubing. Slip a washer over the tube and secure it with solder or epoxy (depending on type container). You want an airtight seal.

A 3/8" vent hose, usually 4 ft. long, is then slipped over the tube. The free end is placed in a quart jar of water. This serves as an airlock, enabling the carbon dioxide to escape while preventing outside air from entering the mash.

Your mash barrel lid should also be airtight, to keep bacteria out. The easiest way to accomplish this, is to simply wrap a length of 2-3" duct tape around the lid perimeter.

DUAL-PURPOSE MASH BARREL

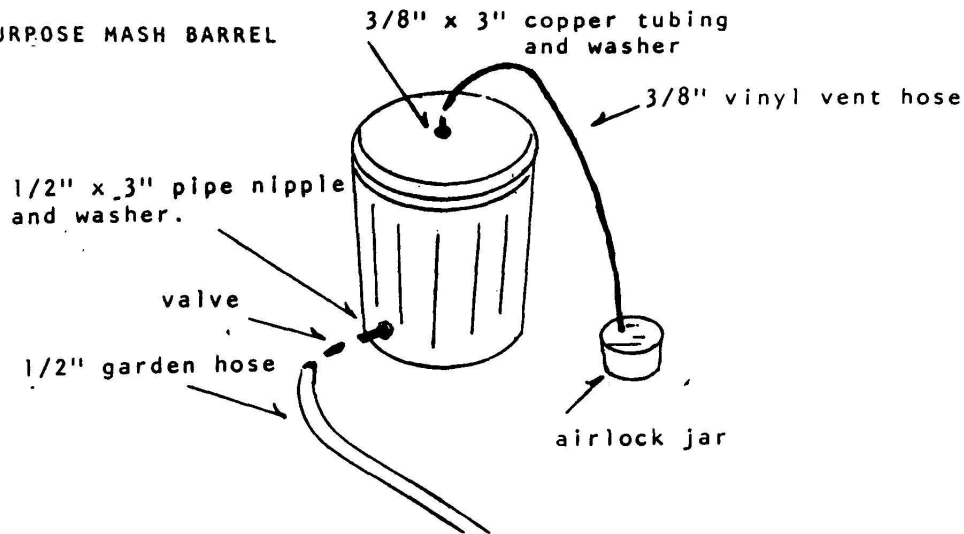

How about mileage? Your ethanol mix contains a substantial percentage of water. The water acts as an extender, not fuel. Therefore, a tankful won't take you quite as far as a tankful of gasoline. You'll come close. Remember, you're running to a large extent, on water. Which should make you feel better!

AQUAHOL VS. GASOHOL

Gasohol, which has received lots of publicity, is like a 10 percent cure for a terminal illness. It consists of 10 percent anhydrous (water-free) alcohol, 90 percent gasoline.

This 200 proof alcohol is more expensive to make than the diluted variety, requiring an elaborate still (or double distilling) to "wring-out" all the water. Water in gasoline, as you know, is a no-no. If used universally, Gasohol could stretch gasoline supplies by 10 percent. Also, even the addition of 10 percent pure alcohol, boosts octane to a point where the usual additives (and catalytic converters) aren't necessary. Gasohol has the advantage, too, of burning satisfactorily without carburetor modification.

The oil companies begrudge even this "inroad," but some are going along with Gasohol—primarily for "PR" (the public knows about it), and because the product can be integrated into the existing distribution framework. Gasohol can be fed into cars through conventional storage tanks and pumps.

Aquahol would, of course, require separate storage facilities and pumps.

Full-strength (200 proof) alcohol can be used "straight" for motor or heating fuel. But, lacking the water "extender," it isn't nearly as efficient or economical as Aquahol. The accompanying table compares pure alcohol with premium gasoline.

RELATIVE FUEL CONSUMPTION	
Methanol, 200 proof	222
Ethanol, 200 proof	161
Premium gasoline	100

As we've pointed out, miles per gallon on a volume basis, are a bit less with ethyl Aquahol, than with gasoline. However, the Aquahol provides considerably better performance. Recent acceleration tests, from 0-60 miles per hour, indicate that 170-190 proof Aquahol has a superiority edge of 15-20 percent. Typical test cars, for example, reach 0-60 in about 18 seconds with gasoline; in 15 seconds, with Aquahol!

Some cars run just fine on a ratio as low as 60% alcohol, 40% water. Heard of the "suppressed" additive that magically transforms water to "gasoline?" You're reading about it!

SECRETS OF A SUCCESSFUL "SAUCE"

There are probably more workable recipes for alky, than for lasagna. All ethanol formulas require a carbohydrate or sugar-loaded raw material, bakers yeast, water, and usually, a varying amount of "outside" sugar.

We've eliminated methanol from your do-it-yourself project. Now, we're going to narrow the parameters even further and limit your initial activity to corn. The reason? Corn, whole kernel or ground, is readily available at reasonable cost. Just as important, following distillation, you'll have a residue (DDGS), which can be sold for cattle feed or fed to your own critters.

If you have sugar beets, fine. Grind 'em up, use the same "grain"/water ratio, and yeast, called for in the recipe that follows, but leave-out the sugar. If you want to use other grains or fruit, sorghum, etc., visit your local library. You should easily find the necessary fermentation information. To list all raw materials and "recipes" here, would require a report the size of a 1960 L.A. phone directory!

Mill this over. In a reasonably fertile soil, you can get 125-140 bushels of corn per acre. As each bushel produces about 5 gallons of Aquahol, that one acre can bring you 600-700 gallons of fuel—enough to drive a car 12-15,000 miles. An acre of sugar beets will produce substantially more "mileage."

THE FERMENTATION PROCESS

After mash has been prepared in your clean barrel, seal lid and place the vent hose in water jar. Barrel must, of course, be in a warm location. Soon, the yeast will start working and a stream of bubbles will exit from the water jar airlock. During this time, don't bump, shake, or jostle barrel, or remove lid. You could bollix the yeast action.

If you've malted the corn, bubbles will probably cease at the end of the third day, meaning that fermentation is completed. Sometimes, however, the bubbles stop for a day or so, then recommence. It's a good idea to wait 12 hours after bubbles stop (especially if bubble action ceases early), before starting distillation.

Another way to tell whether mash is ready for the still, is to see whether the "head" that forms on top of solution, has dropped to the bottom of barrel. This index is practical only when you're using a transparent or translucent container. Remove the lid to peek, and if the layer hasn't dropped, you've opened the door for "bugs" that could stop fermentation.

When the mash has stopped working, strain the solution through clean burlap or cheesecloth. If you're going to use your mash barrel as a still holding-barrel, place the juice in a temporary container.

To modify your barrel for double-duty, simply drill a 1/2" hole close to bottom of barrel, and insert a 1/2" by 3 inch long, pipe nipple and valve. Use a washer over this fitting, secured with epoxy or solder, to form a liquid and airtight seal.

During fermentation, the valve at bottom is shut-off. When the barrel is serving as a juice container while distilling, the escape valve at top must be sealed with a cap, plug, or tape.

BUILDING YOUR SOLAR STILL (See sketches, next page)

If you've envisioned a Rube Goldberg device with pipes sticking-out in all directions, relax. It's simple—in concept, design, and function. And, it works!

Your Solar Still is nothing more than a 4' x 8' x 3/8" (or thicker) sheet of particle board or plywood, with 1" x 4" (actually 3/4" x 3/2") boards screwed or nailed to all four sides. Inside this "box," against the plywood, you glue a 4' x 8' x 3/4" thick sheet of foam (urethane, Technifoam, etc.), for insulation. This foam sheet is then covered, full-length, with household aluminum foil, which you affix with glue. Over the foil, you place a 4' x 8' piece of burlap, dyed black. (Sacks sewed together, work fine.)

The interior side-boards, any exposed wood, are painted black—to absorb sunlight and create maximum heat.

Over the top of your "box," place clear plastic film, rigid transparent plastic, or glass. One works about as well as the other (though glass is best), but the rigid materials are a good deal more costly. Might as well use inexpensive 6 mil film, at least for openers.

This clear covering or glazing, as it's called, must be sealed with tape, putty, Permagum, etc., whichever is most appropriate for the glazing utilized.

Obviously, before you affix the glazing, you have to install the "innards" which transform your 24 to 28 proof juice to 160 to 190 (or thereabouts) proof fuel.

Your still is designed to operate with the long 8' side more or less parallel to the ground, with the left side (as you face it) propped-up so it's about 8" higher than the right side. In the upper left hand corner, near the top, drill a 1/2" inlet hole. Then, take your 99" piece of 1/2" PVC pipe, and drill 1/8" holes, spaced 2" apart, the length of the pipe. Leave the first 3' blank, then commence drilling.

This pipe is inserted into the 1/2" hole at upper left. It runs the entire 8' width of still, close and parallel to, the top 1" x 4" board. The 3" blank pipe extending from left of still, will be hooked-up to the juice feeder line. The right end of pipe is capped, and butts up against the right 1" x 4" board.

When the still is activated, the juice flows from still container into pipe, and down through the holes, into the burlap.

The burlap becomes saturated. The heat inside the still causes the alcohol, which evaporates at lower temperature than water, to leave the solution and collect and condense on the inner surface of the glazing.

As the still is slightly tilted to the right, the alcohol will flow down and to the right. To collect it, we need a "gutter" (1" x 1" corner flashing), which is mounted against and parallel to, the bottom 1" x 4" board. This flashing or "collection gutter" terminates in a 3/8" outlet pipe at the extreme right, lower corner of still. Over this outlet pipe is attached 3/8" vinyl tubing, which carries the alky to a glass or metal collection container. This should be covered, with the lid drilled for inlet tube, to prevent evaporation of your precious spirits. It should also have a small vent hole, for easy in-flow of the alcohol.

Most of the water in your juice won't evaporate as it passes through the burlap, so a separate and larger drain hole must be provided. Drill a 1/2" hole at the bottom right of still, just behind the 3/8" drain hole. Insert a 3" piece of PVC tube into the hole, and anchor it with cement. Slip a 1/2" section of garden hose over pipe, couple it, and place the other end in a second and larger, collection container. This too, should be covered and vented.

This run-off liquid often contains a surprisingly large amount of alcohol. After completing a run, pour this liquid back into your still container for recycling.

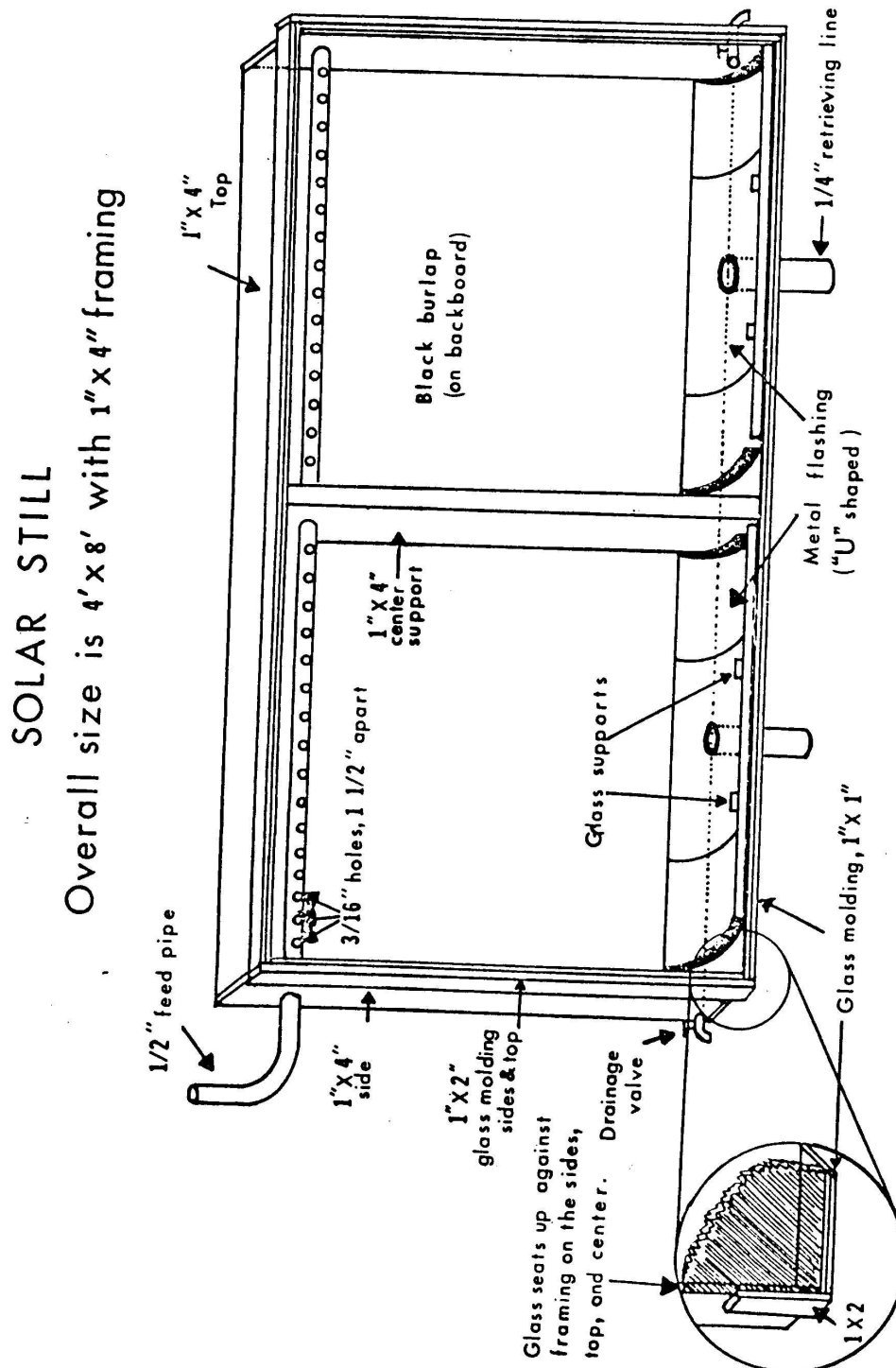

Figure 2.

MATERIALS LIST

Note: Prices may vary somewhat, depending on locale. Those listed are for new materials. Use the recycled variety, and items you have around the house, and your outlay will be even less.

SOLAR STILL

1. One 4' x 8' sheet of 3/8" particle board	\$ 4.10
2. Three pieces, 1" x 4" x 8' lumber @ \$1.04	3.12
3. One sheet, 4' x 8' x 3/4" foam (Technifoam, etc.)	7.00
4. One 8' length, 1" x 1" corner flashing	1.30
5. One 9' length, PVC pipe (sched. 125) with one end cap95
6. One sheet, 4½' x 8½' 6 mil clear film (polyurethane)	1.35
7. Burlap, 4' x 8'	1.00
8. Two boxes black dye	1.20
9. One quart black paint, latex or enamel	3.25
10. One 6" length, 3/8" copper tubing45
11. One box, #10 x 3/4" flat head wood screws90

SIDE VIEW OF SOLAR STILL (45° TILT)

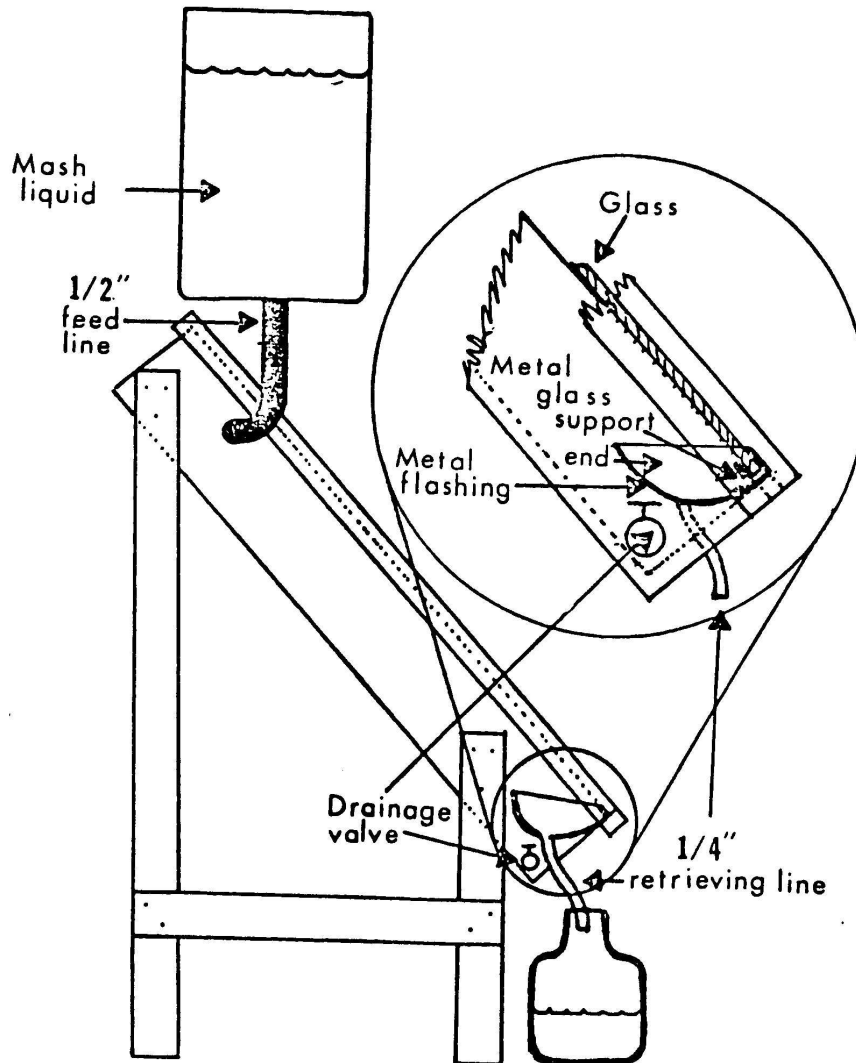

When fermentation is complete, strain mash and pour the juice into clean still container. Open the outlet valve; the degree will depend on the amount of sunlight and outdoor temperature, which govern distillation and flow rates. The hotter the day, the wider you'll open valve.

SUMMING UP THE DISTILLATION PROCESS

The juice runs into still, and dribbles through holes in the PVC pipe, onto the burlap. The heat inside the airtight still "box" causes the alcohol in the juice to evaporate from burlap and condense on inner side of glazing. From there, it runs down to the flashing "gutter," and out through the small outlet tube into collection container.

The remaining water, with some alcohol content, flows down from the burlap to lower right corner of still, and out the larger drain hole into its separate collection container.

STEP-BY-STEP INSTRUCTIONS FOR BUILDING YOUR STILL

We've given you the overall picture. Now, it's up to you. Your still can be a model of craftsmanship, or merely slapped together. You understand the principles involved. So long as they're observed, appearance doesn't count. You may elect to use glass glazing, carefully fitted into dado grooves. Or you may settle for clear film, taped into place. You can miter corners, or simply butt-nail them together. The following procedures will suffice, or they can serve as a starting point.

1. Screw or nail the 1' x 4' boards to all four edges of your 4' x 8' sheet of plywood or particle board. Miter or butt-fit the ends.
2. Affix sheet of 3/4" x 4' x 8' foam with cement, inside "box" and against plywood. Run a bead of caulking material or permagum around edges of foam. Apply aluminum foil to foam with cement, making sure edges overlap to prevent moisture from getting into foam.
3. Cover the foil (and foam) with a 4' x 8' section of black-dyed burlap. Secure it with staples driven into the adjoining wood.
4. Drill a 1/2" hole at top left of frame. Drill a 3/8" hole at bottom right of frame. Drill a 1/2" hole just behind 3/8" hole. (See sketch for relative positioning).
5. Cut PVC 1/2" pipe to 99" length. Leave the first 3" intact. Then drill a series of 1/8" holes, 2" apart, for the remaining 96". Holes should be aligned, and in one side of pipe only. Insert pipe into still through upper left hole, with 1/8" holes facing downward. Cover right end of pipe with cap, then butt it firmly against the right 1" x 4". Secure with cement.
6. Insert 3/8" copper drain tube, and 1/2" PVC drain tube, in holes at lower right. Seal with washers/cement, to prevent leakage.
7. Paint all exposed interior wood, and pipe, with black paint.
8. Install L-shaped 1" flashing. It runs the full 8' length of still, at bottom. (Refer to sketch.) Position flashing so 1/16" extends past the wood. Glazing (film) must bear against this edge. It acts as a barrier, forcing the condensed alcohol down and into "gutter." (If you use glass, flashing must be even with wood.) Secure flashing with wood screws, spaced 12" apart.
9. You're ready to apply glazing. Cut your 6 mil film about 3 to 4 inches oversize, at all sides. Before positioning film, lay a strip of permagum along the length of the protruding flashing edge, to prevent alcohol from seeping past edge. Place film in position, and secure it with vinyl or duct tape. Make certain your film-to-wood seal is as airtight as possible.

POSITIONING STILL

Set your still where it will get the most sun, and with the top tilted back approximately 45 degrees. You can prop it against a fence, old chair, or use hinged legs—bearing in mind that the left side must be about 8" higher than the right. The right side, in turn, must be above the two collection containers, for gravity to do the feeding.

If you enjoy carpentry, make a cradle to guarantee the right sun to still angle, and skew for proper drainage. Set your juice container above still, for gravity feeding, and you're set to go!

We emphasize that our intention now, is to get you started ... to alert you to the fact alcohol is a practical energy source. Experiment, discover how easy it is to make your own fuel, and you may wish to construct a larger or "in-series" solar set-up ... or a still that operates on wood. If you're interested in plans for a wood-burning still, let us know. We've got one in the works!

trimmed in a subsequent step.)

Insert the perforated feeding tube through the 5/8" holes in the top edges of the box so that the 12" unperforated section extends out the left-hand side. Slide a 1/2" collar onto each end of the inserted pipe. Position the pipe so that the perforations face downward as shown and just enough pipe to cap will extend from one side. Seal the space between the pipe and the 5/8" hole inside and out with silicone sealant. Then slide the collars snugly into place against the outside frame on each side and tighten the setting screws on these collars. Using the PVC cement, cap the right-hand end where the perforations begin (the short end of the feeder tube).

Drill a 7/8" diameter hole in the left-hand plastic gutter end cap as shown. Trim the gutter with the hack saw to fit inside the box at the angle shown with its caps pressed in place. Then, use universal (PVC) cement to glue the end caps in place permanently. Now, fold the loose black burlap up and out of the way temporarily, and place the gutter in the proper location at a slight angle as shown. This is the residue delivery trough. Use the retainer nuts and silicone sealant to mount the 6" long, 3/4" diameter nipples in the holes on the bottom edge of the frame as shown. The left-hand nipple will also extend through the hole in the gutter cap. Nipple ends should protrude inside the box as little as possible. Seal and tighten nuts. Then, after being certain that 2" of slope exist along the four foot length of gutter, secure the gutter to the back of the box with the 1/2" wood screws. Allow the sealant to dry overnight, then twist the gate valve onto the male (threaded) to female (smooth) adapter and cement the adapter to the protruding end of the feeder tube. This will be used to regulate the in-flow of distillable solution.

Next, fold the burlap back down over the gutter and trim it with the utility knife or a pair of scissors so that the bottom edge hangs about 1" above the bottom of the sloping delivery trough. Secure the burlap in place in a few places to keep it from moving around when the finished still is moved later on. But, avoid stapling the bottom edge of the burlap at all.

Finally, place a bead of sealant along the facing edge of the frame and lay the sheet of 4' x 8' glass into place. Secure the glass panel with the aluminum molding. For a finished look, miter the corners of the molding at a 45 degree angle. Anchor the molding in place with its mounting screws. The still is now complete. It will operate for many years on the power of the sun alone. You may construct a stand for it, or prop it against a building or other structure at the optimum angle. The optimum angle for maximum solar energy is as follows.

WINTER	Local latitude plus 15 degrees
SPRING	Local latitude
SUMMER	Local latitude minus 15 degrees
AUTUMN	Local latitude

The direction the still faces should be due geographic south.

USING YOUR STILL

Now that you have a still ready for use and, hopefully, government registered, it is time to distill some alcohol fuel. The actual use of your still can range from simple, to highly creative. Gravity flow of mash solution is the easiest approach. A feeding tube or feeding pipe from your mash solution holding tank can simply be regulated to provide a constant supply of distillable solution. The operating temperature of both types of still (solar and WW 500)

INSTANT ETHANOL

SOLAR STILL DIAGRAMS

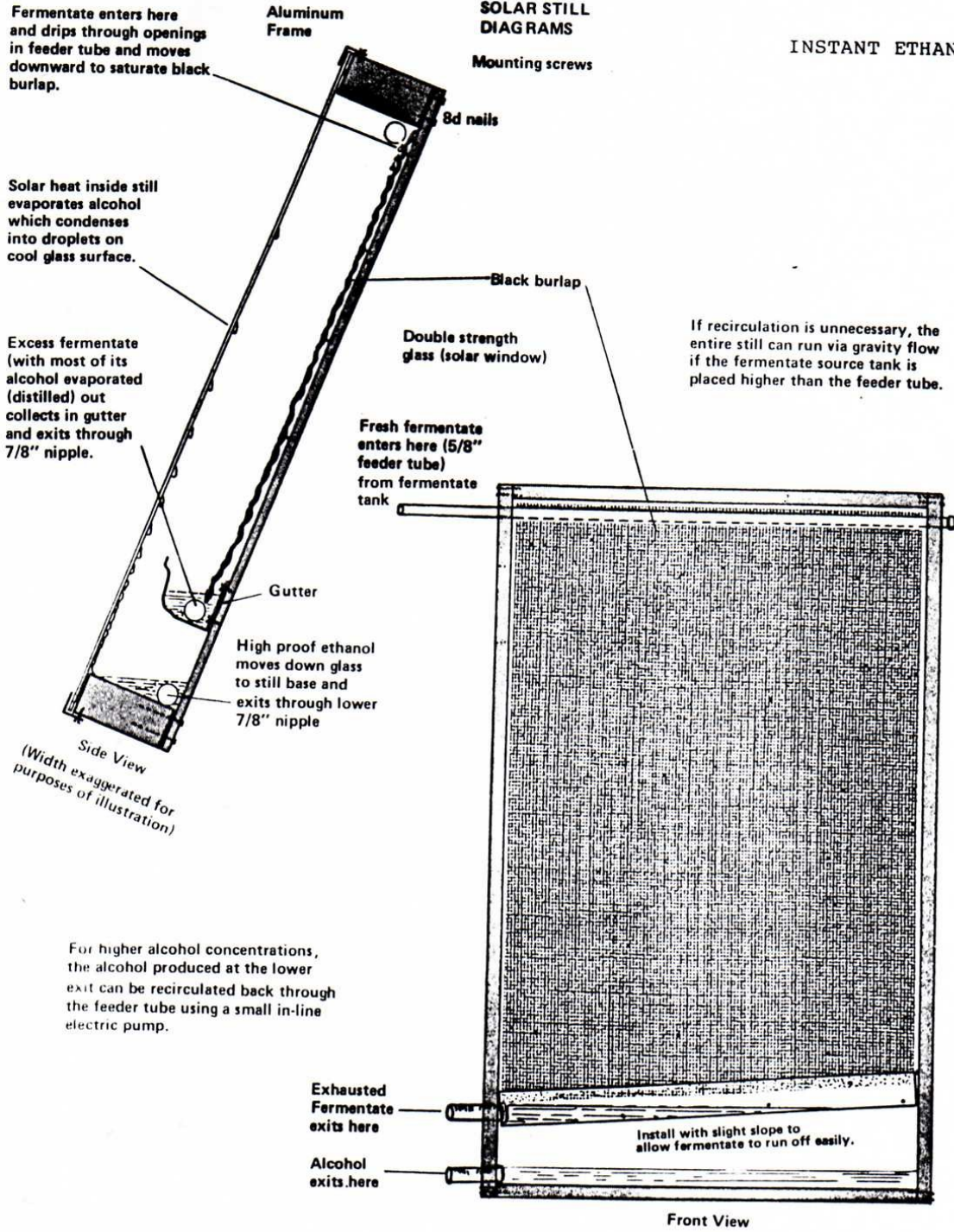

For higher alcohol concentrations, the alcohol produced at the lower exit can be recirculated back through the feeder tube using a small in-line electric pump.

FERMENTATION

Alcohol can be produced from a surprising range of raw materials...from corn, to peaches, to potatoes, to artichokes, to old newspapers. Critics of domestic alcohol production from plant and vegetable matter argue that at the current cost of a bushel of corn (about \$4.50) as an alcohol feedstock would produce ethanol with cost per gallon of \$1.50 for the ingredients alone!

Now the good news. First, new enzymes and yeast strains have helped to drastically increase the alcohol yield from a bushel of grain. Second, ingredients, millions of tons of ingredients across the country, are available without cost. Spoiled grains, rotten fruits, waste paper, and all manner of refuse either cost nothing...or may be hauled away to an alcohol production plant at a slight profit (garbage collection fees). It is amazing how abundant free feedstock materials are. In my own community, with just a little checking, I've found enough free and clean ingredients to produce several thousand gallons of ethanol every week. It is reasonable to expect that you can do just as well in your community.

For example, a local weekly newspaper publisher can find no market for more than 50 tons of waste newsprint each year. He pays a small fee to have it hauled away just to keep his building clean and free of the unwanted accumulation of trimmings and end-rolls. Newsprint is almost pure cellulose, which can easily be converted by nearly 100% to simple, fermentable sugars with the latest enzymes. Dry paper is a remarkably clean, odorless feedstock material that can be stored indefinitely. And, the alcohol yield per ton is quite high. A paper-shredder is all that might be necessary to process this material for fermentation. And old newsprint from a variety of sources is available in nearly every community in the country.

Special sources of free feedstock materials present themselves uniquely in each different area. Until now, you may have taken many of these important local sources of alcohol for granted...without realizing their potential. So, let us consider the various types of feedstocks and how they may be used.

There are three general categories of ethanol feedstocks: SACCHARINE MATERIALS (high in natural sugar content), STARCHY MATERIALS, and CELLULOSE MATERIALS. There are also a number of ingredients containing two or all three of these materials together. Each type of material has its own, special processing recipe.

SACCHARINE FEEDSTOCKS

These are the simplest types of materials to ferment. They are simply (1) ground or crushed (to expose the greatest surface area to the yeast organisms, (2) Adjusted for correct pH (acidity or alkalinity) level (by the addition of a small amount of acid...or some of the previous fermenting material), and (3) fermented for 2 to 7 days (depending on temperature and the type of material used).

One more consideration is necessary for saccharine materials...the percentage of fermentable sugar present. About 50% of the fermentable material will be converted to alcohol by fermentation. As discussed earlier, the yeast organisms responsible for this conversion can usually only tolerate a 10% concentration. Therefore, the original sugar content should not exceed 20%. If the original concentration is higher than this, some of the potentially fermentable material will not be converted before the process stops...thereby causing waste of feedstock material. This is, of course, undesirable. It is therefore important

to estimate the sugar percentage prior to distillation, and, when necessary (as with super-rich sugar materials, such as molasses) the fermenting solution should be diluted to the optimum level of 20%.

Over dilution is just as undesirable as under dilution because more distillation time will be required to remove the excess water. For example, a ton of grapes, with 15% sugar content would yield about 17 gallons of nearly pure alcohol. But watermelons, containing only 2% to 3% sugar would yield only about 3.5 gallons of alcohol...in the same amount of distillation time.

Actual measurement of the sugar content of the fermentate (fermenting solution) can be measured in advance with a "hydrometer" (available from chemical supply houses and wine-making apparatus stores. See the directory in the back of the book for mail order sources of this and other supplies.) However, since no saccharine materials (with the exception of molasses at 50-55%) have sugar concentrations exceeding 20%, pre-fermentation measurement of the sugar content for these items is not necessary. (Actual recipes included later are carefully configured to eliminate any need for dilution.)

The following table list the most common saccharine materials and their sugar content:

TOMATOES	2.0%	PRICKLY PEAR	4.3%
ORANGES	5.4%	WATERMELON	2.5%
APPLES	12.2%	PINEAPPLES	11.7%
GRAPES	15.0%	PEACHES	7.6%
BANANAS	13.8%	PEARS	10.0%
CANE SORGHUM	14.0%	MOLASSES	50.0%+
SUGAR BEETS	15.0%	CORN STALKS	8-15%

Once most fruits have been crushed, a small amount of acid should be added to bring their pH level to 4.8 to 5.0. The pH scale ranges from 1-14 with 7 as neutral, 1-7 acid, and 7-14 as alkaline. Most fruits are naturally alkaline and will need the addition of a common acid such as sulfuric acid (the kind in car batteries...and available at most garages) or hydrochloric acid (the type used in swimming pools and available from any pool supplier). If you add too much acid, the excess amount may be neutralized with a small amount of ordinary lye (NaOH or sodium hydroxide).

Fermentates above the pH 5.0 level will begin to grow large quantities of bacteria which are harmful to yeast and the fermentation process in general. These bacteria produce lactic acid which reduces the alcohol yield. Below the pH 4.0 level, the yeast begins to die...and other detrimental reactions occur. As complicated as all this sounds, the pH of your solution can be easily tested with pH paper (available from swimming pool suppliers), and controlled with small amounts of acid or lye.

Once the pH is at the proper level, add about 2 pounds of yeast for each 1000 gallons of fermentate. To provide proper nutrition for the yeast, backslop 25% (add about 25% of the solution from the previous batch of fermentate after it has had its alcohol removed via distillation. The materials present in this prior fermented solution will increase the alcohol yield in subsequent batches. Naturally, this cannot be done with your very first batch.)

The optimum temperature for fermentation is, conveniently, room temperature (70-85 degrees F.) The temperature of the fermentate should not be allowed to exceed 90 to 95 degrees F., or the yeast will begin to die. Once the yeast has been added, fermentation will begin. And, within 2 to 7 days...the process will be complete.

Cane sorghum is a good feedstock. But, unlike most fruits, it has the disadvantage of requiring shredding or pressing with heavy, hydraulic presses to extract the fermentable material. For a large industrial operation which could justify the cost of such equipment, the feedstock material presents no problem. But, for the small distiller, it may not be practical.

Molasses is an excellent feedstock material that can yield as much as 75 gallons of alcohol per ton. No additional extraction is necessary. But, as mentioned above, dilution will be necessary. Also, backslopping of up to 50% is necessary since molasses is very low in yeast nutrients. Use the same fermentation process and tolerances as mentioned above. The addition of acid will be necessary.

Sugar beets are mostly sugar and water...a perfect combination for alcohol production. They may be crushed like fruits or pressed like canes. Their fermentate solutions should be backslopped by about 20%. And, because they do contain some starches, the addition of a starch-conversion enzyme such as malt will boost alcohol production from this feedstock. (See the section on processing starches below.) Yield: up to 25 gallons of alcohol per ton.

Stalks from sugar corn are an excellent feedstock, widely available, and almost always free. While they require the same extraction as sugar cane or cane sorghum, their sugar can also be extracted by chopping and boiling them. Or they can be used in chopped form with other ingredients in a fermentate recipe without any further preparation. However, none of the cellulose in the stalks or any other green plant material is converted when used unprepared in raw, chopped form. To enhance alcohol production, add a small quantity of the enzymes mentioned in the section on cellulose feedstocks listed below.

STARCH FEEDSTOCKS

These materials are high in "potential" sugar content. But, they must usually be milled, cooked and converted from starch to sugar with an enzyme to be used. With grains, these steps can be minimized or eliminated if the grains are first sprouted by soaking them in warm water for 12 to 15 hours then pouring the wet grain into half-filled burlap sacks and watering them frequently for 4 to 5 days. Most grains have a high starch content. Maize, wheat, rye, oats, sorghum seed, corn, milo and barley have starch contents of 50% to 65%. For the small distiller who does not wish to employ sprouting, use meal made from any of the above grains.

Potatoes and sweet potatoes are, of course, high in starch and may be used even if spoiled or sprouted. In fact they are superior for fermentation in this form...requiring less enzyme for conversion. They must be cooked...but need not be milled prior to conversion. Potatoes offer about 16% to 18% fermentable material. Sweet potatoes deliver about 22% starch plus the added bonus of another 5% sugar for a total fermentable material percentage of 27%. A final starchy feedstock worth mentioning is the Jerusalem artichoke which, if cooked long enough, can be fermented without the need of enzymatic conversion. Fermentable content: 17%.

CELLULOSE FEEDSTOCKS

These materials may be converted to sugar through a variety of processes...some very complex. We'll discuss the simplest process here using some of the newest enzymes. Novo Laboratories produces two important enzymes for cellulose conversion: "Cellulast" which converts about half the cellulose to sugar and "Cellobiase" which converts most of the other half. So that these

enzymes will be able to work properly, the cellulose material needs to be shredded or ground. This is very easy to do with paper products.

Next, a little water is added to form a thick paper stew. The pH is then adjusted to the optimum level (4.5 to 5.0) and both enzymes are added according to the following formula. 2% Cellulast and .2% Cellobiase by weight to 98% (approximately) of the amount of actual cellulose present. Sawdust may contain 5% cellulose while newsprint contains up to 80%. Thus, 5% x 2% or .1% would be the proper percentage of Cellulast in sawdust solutions. And, 80% x 2% or 1.6% for newsprint solutions.

Ideal temperature for the enzyme reaction is about 140 degrees F. for 16 hours. Then the temperature may be reduced to the 70-90 degree F. range for fermentation in the usual manner.

FERMENTATION

In summary, here is the optimum fermentation environment. Temperature: 70 to not more than 90 degrees F. The pH should be between 4.8 and 5.0, ideally. The cleanliness of the fermentation equipment is also essential...since the accumulation of bacteria can substantially limit alcohol production. For large operations, steam cleaning is effective. For the small distiller, cleaning with a strong disinfectant is satisfactory. Formaldehyde and ammonia are cheap and effective cleaners for this purpose. After disinfecting, all apparatus should be rinsed thoroughly in clean water in preparation for the next batch of fermentate.

Special equipment necessary for the fermentation portion of the alcohol production process may include the following:

- * A hydrometer (for measuring sugar & alcohol content levels. It looks like a floating thermometer.)
- * A hydrometer conversion table or booklet (available free from the Bureau of Alcohol, Tobacco, and Firearms. Temperature variations and other factors affect hydrometer readings. With a table, precise information is always available.)
- * pH paper or testing solution (for pH regulation)
- * Some type of distillation vat. Large plastic garbage cans with a trash bag as a vat liner are light, easy to use, waterproof, and easy to clean. Be sure to drill a vent hole or two in the lid if a vent is not already present.
- * Optional, a fermentation lock (pictured below). These permit the release of carbon dioxide without the loss of alcohol vapors. Small ones are available from wine-making suppliers. But, you should make a larger one of your own for vats larger than 5 gallons... if alcohol vapor loss is presenting a problem in your particular situation. In many instances a lock is not necessary.
- * A Strainer (to remove the plant residue from the fermented solution prior to distillation. Fine wire mesh or washed burlap attached to a wooden frame or hoop the same size as the top of a vat provide a very convenient strainer. Solid residue makes excellent garden fertilizer.)
- * Various enzymes as needed, eg. Cellulast, Cellobiase, malt, etc. (Only necessary when fermenting dry milled grains, potatoes and other starchy feedstocks, or materials with a high cellulose content.)
- * Acid (hydrochloric or sulfuric) for acidization of fermentate.

SUGAR BEET CRUSH

40 pounds of totally crushed sugar beets (tops and all)

1 pound yeast or 5-10 gallons of backslop
(Deduct backslop quantity from water specified below.)

40 gallons of water warmed to at least 70 degrees F.

Combine ingredients as specified above and ferment 2 to 7 days.

BLACK MOLASSES VELVET

Sufficient molasses to produce an initial sugar content of 20%.
(in 50 gallons of water. Use your hydrometer and a conversion table to determine the exact amount.)

1/4 pound ammonium nitrate (nitrogen fertilizer pellets).
(This provide nutrition for the yeast.)

1 pound yeast (or 5-10 gallons of backslop)
(Deduct backslop quantity from water specified below.)

50 gallons of water warmed to at least 70 degrees F.

Combine ingredients as specified above and ferment 2 to 5 days.

SPROUTED SURPRISE

60 pounds of any grain

1 pound yeast & 1/4 pound nitrogen (or backslop 5-10 gallons)
(Deduct backslop quantity from water specified below.)

40 gallons of water warmed to at least 70 degrees F.

Sprout grain using procedure outlined in STARCHY FEEDSTOCKS section. When sprouts reach 2 inches in length, grind and mix with water and yeast & nitrogen or backslop solution. Ferment for 3 to 7 days. Strain, and distill.

Recipe #1

SWEET GREEN GOODNESS

60 pounds of green vegetable matter
Chopped corn ears & stalks (entire plant)
or, grass clippings
or, chopped weeds
or, any other plant matter that is green & juicy

20 pounds crushed sugar beets (or, sugar cane)
or, 8 pounds sugar (or, molasses)

1 pound yeast (first batch only).
(Use 5-10 gallons of backslop on subsequent batches.)
(Deduct the number of gallons of backslop from the amount of water specified below.)

40 gallons of water warmed to at least 70 degrees F,

Mix all ingredients except yeast in vat. Check for temperature range of not less than 70 degrees F. and not more than 90 degrees F. Then, mix in yeast, and cover. Keep at above temperature range for 2 to 7 days. When a few bubbles appear, test alcohol content with hydrometer. When alcohol level reaches 10% to 12%, strain solution through wire mesh or washed burlap and prepare for distillation.

HYDROMETER

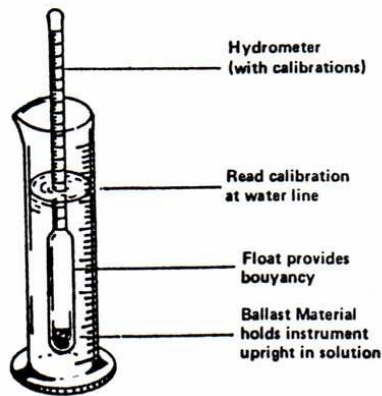

FERMENTATION LOCK

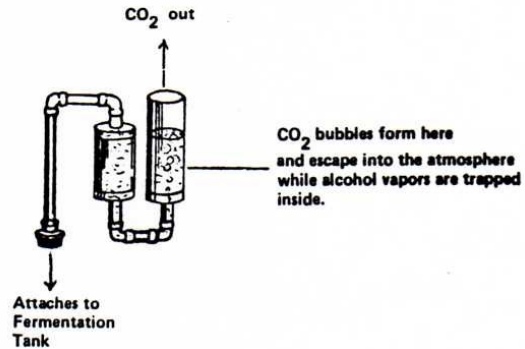

* Lye (for acid neutralization when necessary).

With this equipment, you can produce as much alcohol as you wish in a relatively small space. Plastic garbage cans are, in my opinion, the most convenient container for the small producer. Any type of container may be used however--old sinks or bathtubs, 55-gallon drums, etc. If you are using a material that requires cooking or conversion at a higher temperatures, a 55-gallon drum built over a brick fire box can be an excellent combination (allowing the same vat to be used for cooking and distilling).

The entire fermentation process requires from 36 hours to as long as seven days. Fermentation is over when the hydrometer reading shows that half of the estimated initial sugar content has been converted to alcohol. The recipes below are designed to produce a resulting alcohol content of not more than 12% (which can be tolerated by the newest yeast strains). By back slopping some of the exhausted fermentate into the next batch of material...yeast and yeast nutrients (such as nitrogen) need not be added. They will grow in a continuous process from one batch to the next.

In some locations, maintaining the right fermentation temperature may be difficult. If some cooling of the fermentate is necessary, a garden hose may be connected to a source of cool water. Place most of the hose into the vat and place the end of the hose in a drain (or in a garden irrigation ditch, if you wish to reclaim the water). Then run cool water through the hose until the temperature in the vat reaches the level desired. The same technique can be used to warm the fermentate, by running hot water through the hose.

UTILIZATION OF ALCOHOL FUELS

HEAT YOUR HOME WITH ETHANOL

Most oil burners will run well on 130 proof alcohol. A little experimentation may be required, but in most cases, little modification is necessary. On some models, the air intake valve may need to be adjusted (something which oil heater owners do frequently anyway). On others, the fuel in-flow valve may need adjustment. Next, it is necessary to drain the oil tank. No cleaning is necessary. Just be sure that no appreciable amount of oil remains. Finally, start your furnace normally and make any necessary valve adjustments as mentioned above. You and your family will appreciate the clean-burning results that come from conversion to ethanol heating fuel.

As a footnote to this section, it should be noted that a rather large quantity of ethanol will be needed to heat your home all winter long. Unless you have enough space and materials to produce a lot of fuel, you may find it best to conserve the ethanol you make for use in your vehicles.

CONVERTING SMALL ONE AND TWO-CYCLE ENGINES

One of the simplest engines to be found in most households is the lawn mower. You won't need to be a mechanic to convert this one. The adjustment of the fuel regulation screw to allow more fuel to enter the engine should be all it takes. If you have no idea where this screw is located, ask a neighbor or your gardening supply dealer. This will be your first opportunity to see the extra power available from alcohol fuel. Tall, thick grass may have been too much for a full swath with your mower when it was powered by gasoline. But, with ethyl alcohol, your mower will cut more grass without stalling. You'll take fewer steps, finish in less time, and experience fewer engine problems. (And your mower will run cooler and more quietly.)

There are a couple of things to keep in mind. First, the varnish that builds up in your lawn mower when you used gasoline will be dissolved when you begin running on ethanol. This might cause the gas line to clog the first few times as layers of varnish are dissolved and move down the gasline to the carburetor. By cleaning the little filter screen for the first few uses, you will eliminate the fuel-line clog problem forever afterward...since alcohol won't produce varnish.

The second thing to watch for is cold starting. At temperatures below 50 degrees F., an alcohol-powered mower may begin to be difficult to start...due to the low volatility of ethanol. Since lawns seldom need mowing on cold days, this may not be a problem in most areas. However, if you need to get things started and the air temperature is too low, here's a simple technique. Loosen the knob on the air filter (it can often be removed by hand without a screwdriver). Then give it a shot of "pentane" or "ether" (available from most auto supply stores) from an aerosol can. Presto. Instant Ignition.

These same techniques may work on small motorcycles, scooters, go-carts, etc. If additional adjustments seem necessary, consider some of the suggestions in a following section.

DIESEL ENGINES

Chemically, diesel engines will run well on ethyl alcohol without conversion, contrary to the opinion of most experts. (BJ and the Bear do it all the time.) Proof levels of 140 may even be satisfactory. But, there is usually insufficient lubrication of the injectors when pure alcohol is used over a prolonged period. This condition can be resolved by:

- * Adding 20% vegetable oil to the ethanol fuel,

MODIFYING YOUR CAR FOR AQUAHOL

A variety of tests have indicated that satisfactory automotive performance occurs with 160-190 proof ethanol. Your product should be in this range. If you want to determine the exact proof of your mix, get a 0-200 hydrometer. They're available at wine supply shops, and sometimes, through wholesale auto parts houses. (The same manufacturers make "anti-freeze" instruments.)

As we've mentioned, alcohol as a fuel has many advantages. Its only disadvantage is a possible problem in cold weather starting. Because alcohol vaporizes more slowly than gasoline, and slower yet in cold climes, your engine may need an assist when the temperature nears freezing.

The easiest way to assure fast starts is to buy a windshield cleaner kit. New, they cost about \$6.95 at any auto parts store. Or you can get a used unit at a wrecking yard for a buck or two. Mount it under hood, and position and fasten the outlet tube so it points into the carburetor throat. Fill the plastic container with gasoline. A squirt or two will start your engine, pronto! It may run somewhat rough until operating temperature edges upward. Then, your engine will purr on its new alcohol diet.

A second requirement is a larger main jet in carburetor (or jets in a multi-throat carb). Alcohol has more volume per burnable fluid, than gasoline. So, you have to get more of the stuff into the carburetor at a given time. Use your regular jet(s), and engine will balk, backfire, and otherwise cause a fuss.

Generally, for Aquahol, holes 40 percent larger than normal, are the ticket. If, for example, your present jet is .056 in diameter, you can enlarge it to .0784" (about 40%) with a #47 drill. You might start by expanding hole by 30% or so, then working your way up and test driving car after each drilling, until you get optimum results.

Make the hole too large, and you'll waste fuel. An index as to whether the hole is too small, even though car appears to operate normally, is a white film on spark plug electrodes. This means the engine is running too hot. With the proper jet aperture, plugs will have a light tan coating.

While you have the carburetor apart, remove or tie-back the automatic choke, and install a manual, under-dash unit. (See sample ad.) You need this type to make certain your carb is open when you pump in gasoline on cold mornings. Also, it permits you to "fine-tune" your ethanol/air mixture for better performance and economy, when changes occur in weather and altitude.



You'll probably want the capability of changing over to gasoline. Then, get a standard carburetor from an auto graveyard. Install it, hook-up your automatic or manual choke, and run-out or drain the alky in your tank. Change-over should take only 20 minutes or so.

Sometimes, not always, an alcohol powered car runs better with the spark plug gap slightly reduced—usually by no more than .006". Experiment. This small change may make all the difference in the world!

STATE LISTING OF ALCOHOL FUEL INFORMATION OFFICES

- ALABAMA**
Fred Braswell, Program Coordinator, Energy Management Board, 3734 Atlanta Hwy., Montgomery, Ala. 36130
- ALASKA**
Paula Wellen, Community Information Center, Fairbanks North Star Borough, 520 Fifth Ave., Fairbanks, Alaska 99707
- ARIZONA**
Richard Wetzel, Office of Economic Planning and Development, 1700 W. Washington, Executive Tower 505, Phoenix, Ariz. 85007
- ARKANSAS**
Alford Drinkwater, Biomass/Resource Recovery Coordinator, Department of Energy, 3000 Kavanough, Little Rock, Ark. 72205
- CALIFORNIA**
Manual R. Espinoza, Department of Alcoholic Beverage Control, 1215 O St., Sacramento, Calif. 95814
- COLORADO**
Bob Marten, Department of Agriculture, 525 Sherman St., 4th Floor, Denver, Colo. 80203
- CONNECTICUT**
Joe Belonger, Energy Research and Policy, 81 Washington St., Hartford, Conn. 06113
- DELAWARE**
Dan Antline, Energy Office, P.O. Box 1401, 114 W. Water St., Dover, Del. 19901
- FLORIDA**
Will Kirksey, Governor's Energy Office, 301 Bryant Bldg., Tallahassee, Fla. 32301
- GEORGIA**
Rob Harvey, Office of Energy Resources, 270 Washington St., S.W., Room 615, Atlanta, Ga. 30334
- HAWAII**
Takeishi Yoshihara, Department of Energy, 4322 Prince Kuhio Federal Bldg., Honolulu, Hawaii 96850
- IDAHO**
Gail Dameworth, Idaho Office of Energy, State House Mail, Boise, Idaho 83720
- ILLINOIS**
Nicholas P. Hall, Alcohol Fuels, Program, Room 300, 325 W. Adams St., Springfield, Ill. 62706
- INDIANA**
Mary Failey, Department of Commerce, 440 North Meriden, Indianapolis, Ind. 46201
- IOWA**
Doug Gatter, Iowa Development Commission, Dept. TMEN, 250 Jewett Bldg., Des Moines, Iowa 50309
- KANSAS**
Randy Noon, State Energy Office, 214 W. 6th St., Topeka, Kan. 66603
- KENTUCKY**
Bruce Sauer, Department of Energy, P.O. Box 11888, Lexington, Ky. 40578
- LOUISIANA**
Thomas C. Landrum, Department of Natural Resources, P.O. Box 44156, Capitol Station, Baton Rouge, La. 70804
- MAINE**
Nancy Holmes, Office of Energy Resources, 55 Capitol St., Augusta, Maine 04330
- MARYLAND**
Marvin Band, Office of Public Affairs, P.O. Box 466, Annapolis, Md. 21404
- MASSACHUSETTS**
Chris Hansen, Office of Energy Resources, 73 Tremont St., Boston, Mass. 02108
- MICHIGAN**
Randy Harmon, Energy Coordinator, Department of Agriculture, P.O. Box 30017, Lansing, Mich. 48909
- MINNESOTA**
Dennis M. Devereaux, Alternative Energy Projects, 980 American Center Bldg., 150 East Kellogg Blvd., St. Paul, Minn. 55101
- MISSISSIPPI**
Robert Smita, Department of Natural Resources, 300 Watkins Bldg., 510 George St., Jackson, Miss. 39202
- MISSOURI**
Deborah Goldhammer, Division of Energy, P.O. Box 176, Jefferson City, Mo. 65102
- MONTANA**
Georgia Brensbal, Program Engineer, Department of Natural Resources, 32 South Ewing, Helena, Mont. 59601
- NEBRASKA**
Steve Sorum, Agricultural Products Industrial Utilization Committee, 301 Centennial Mall, South 3rd Floor, Lincoln, Neb. 68509
- NEVADA**
Kelly Jackson, Nevada Department of Energy, 400 W. King St., Room 106, Carson City, Nev. 89710
- NEW HAMPSHIRE**
Tina Oleson, Government's Council on Energy, 1/2 Beacon St., Concord, N.H. 03310
- NEW JERSEY**
Louis Jatecki, Department of Energy, 101 Commerce St., Newark, N.J. 07102
- NEW MEXICO**
Charles P. Wood, Energy Resource & Development Division, P.O. Box 2770, Santa Fe, N.M. 87501
- NEW YORK**
Mark Bagdon, State Energy Office, Agency Building 2, Rockefeller Plaza, Albany, N.Y. 12210
- NORTH CAROLINA**
John Manuel, Energy Division, Department of Commerce, P.O. Box 25249, Raleigh, N.C. 27611
- NORTH DAKOTA**
John G. Conrad, Energy Conservation Programs, Federal Aid Office, State Capitol, Bismarck, N.D. 58505
- OKLAHOMA**
Rex Privett, State Department of Energy, 4400 N. Lincoln Blvd., Suite 35, Oklahoma City, Okla. 73105
- OREGON**
Richard L. Durham, Department of Energy, 102 Labor and Industries Bldg., Salem, Ore. 97310
- PENNSYLVANIA**
Shelly Analyst, Minority Research Unit, House of Representatives, Box 250, Harrisburg, Pa. 17120
- RHODE ISLAND**
Shelly Greenfield, Governor's Energy Office, 80 Dean St., Providence, R.I. 02903
- SOUTH CAROLINA**
Cathy Twilley, Division of Energy Resources, 1122 Lady St., Columbia, S.C. 29201
- SOUTH DAKOTA**
Verna Brokka, Office of Energy, Pierre, S.D. 57501
- TENNESSEE**
Margot Myrick, Legislative Plaza, Suite 2, Nashville, Tenn. 37219
- TEXAS**
Bob Avant, Energy and Natural Resources Advisory Council, 411 W. 13th St., Suite 900, Austin, Tex. 78701
- UTAH**
Jim Bryne, Utah Energy Office, 231 E. 400 South, Salt Lake City, Utah 84111
- VERMONT**
Larry Ogden, State Energy Office, State Office Bldg., Montpelier, Vt. 05602
- VIRGINIA**
I. Smith, Department of Agriculture & Consumer Services, 203 N. Governors St., Richmond, Va. 23219
- WASHINGTON**
Paul Juhasz, State Energy Office, 400 E. Union St., Olympia, Wash. 98504
- WEST VIRGINIA**
Rebecca Scott, Fuel and Energy Office, 1262 1/2 Greenbriar St., Charleston, W. Va. 25311
- WISCONSIN**
George Plaza, Division of State Energy, 101 S. Webster St., Madison, Wis. 53702
- WYOMING**
Butch Keadle, Energy Conservation Office, Capitol Hill Office Bldg., 25th and Pioneer, Cheyenne, Wyo. 80002
- DISTRICT OF COLUMBIA**
Program Director, D.C. Energy Unit, Suite 200, 1420 New York Ave. N.W., Washington, D.C. 20005

GETTING ALONG WITH UNCLE SAM . . .

As you probably know, it's illegal to make "shine"—alcohol distilled for human consumption. Your product is essentially the same, but for a different and certainly more commendable, purpose. In view of the energy crunch and the growing number of people making their own fuel, the BATF (Bureau of Alcohol, Tobacco and Firearms) now grants experimental permits for a small fee. As long as you're making fuel, not "white lightning" for low-cost whoopee, bureau personnel are for the most part, helpful, cooperative, and vitally interested in this "shining" example of American ingenuity.

The first thing to do, before you start distillation, is to write:

FOR FEDERAL INFORMATION

**Mr. T. P. McFadden, Chief
Industry Control Division
Department of the Treasury,
Bureau of Alcohol, Tobacco, Firearms
Washington, DC 20226**

FOR STATE INFORMATION

Paste-in State
Office, here

Your letter should request "permission to set-up an experimental still for the purpose of distilling alcoholic spirits, per Title 27, Code of Federal Regulations, Section 201.65." In addition, mention your proposed heat source (solar), raw materials (corn, sugar beets, etc.), and most important, how your alcohol will be utilized (as automotive and heating fuel).

You'll soon receive forms, requesting location and size of your still, its impact on the environment, etc. If you have any questions, or need help in completing forms, call your regional BATF office. Chances are you'll be set straight over the phone.

Likely, a friendly inspector will drop by to see your plant and perhaps, furnish helpful advice. The important thing to remember is, don't screw-up the works for yourself and others by using or selling, your product as a beverage. It's taken many months to gain the present confidence and cooperation of the BATF on home stills. Just a few illegal operations could entangle all still owners, present and future, in a web of red tape.

It's also a good idea to check with the state energy office listed above, for information on state regulations, permits required (if any), income tax breaks, etc. A note or phone call will bring the details.

PERFORMANCE

Ethanol is consumed 15% to 18% faster than gasoline in internal combustion engines. But additional power of about the same magnitude is also delivered. Your car will have a higher maximum speed, climb hills more easily, and never, ever knock (even on hills). It is the extra power advantage that has made alcohol such a popular racing fuel. (Less powerful but more readily available methanol is usually used.) Once the proper adjustments have been made, you will be noticeably impressed with your car's performance using this renewable fuel that you make yourself.

ENZYME AND YEAST SUPPLIERS.

Anheuser-Busch, Inc.
721 Pestalozzi Street
St. Louis, Missouri 63118

C.B. Fermentation Industries,
Inc.
One North Broadway
Des Plaines, Illinois 60016

Nova Laboratories Inc.
59 Danbury Road
Wilton, Connecticut 06897

Biocon (U.S.), Inc.
261 Midland Avenue
Lexington, Kentucky 40507

Miles Laboratories Inc.
Masschall Drive
Elkhart, Indiana 46514

Red Star Yeast
Universal Foods Corp.
433 East Michigan Street
Milwaukee, Wisconsin 53201